

DISCRETE DIFFERENTIAL
GEOMETRY:
AN APPLIED INTRODUCTION
Keenan Crane • CMU 15-458/858

LECTURE 7:
EXTERIOR CALCULUS — INTEGRATION

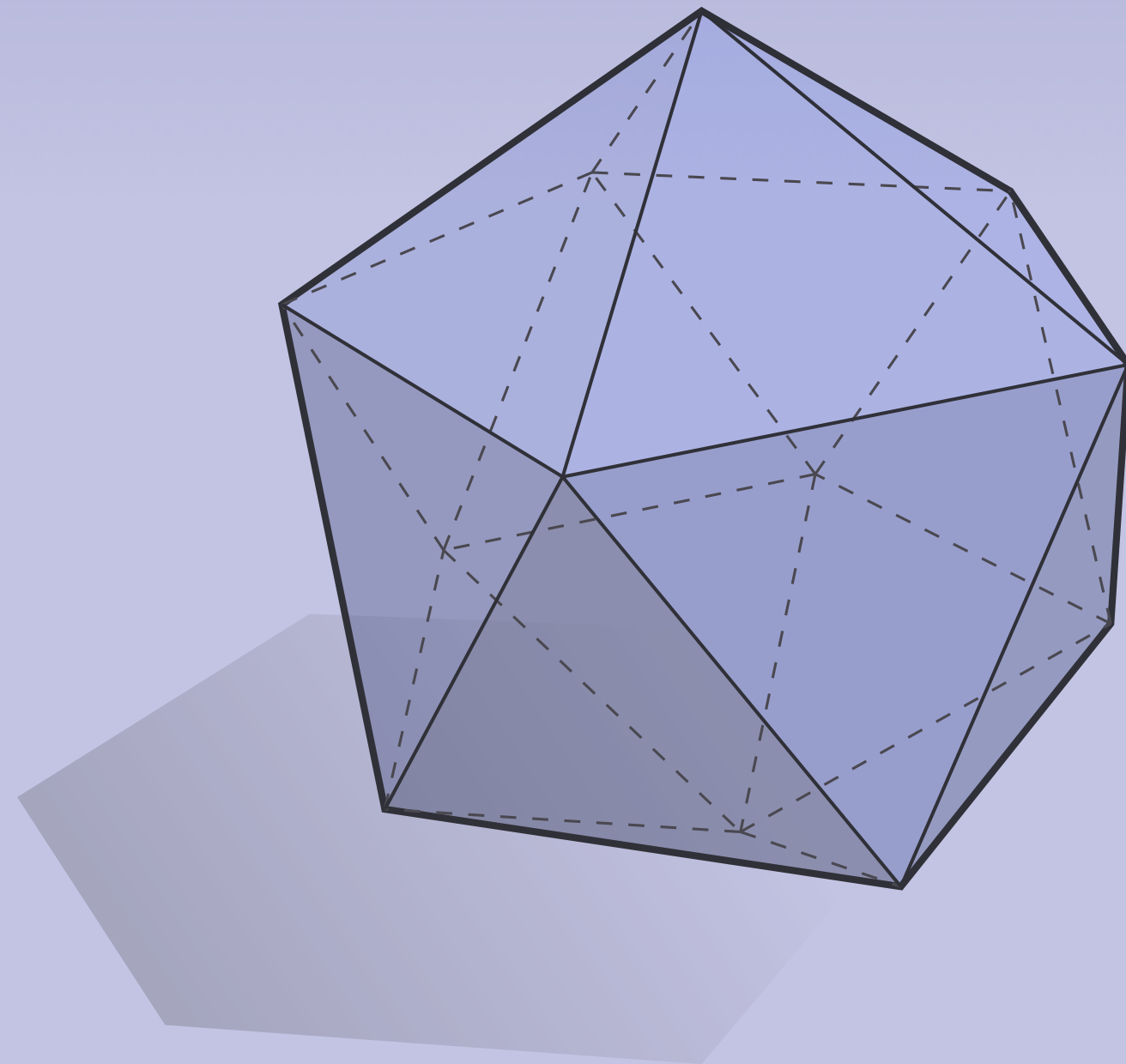

DISCRETE DIFFERENTIAL
GEOMETRY:
AN APPLIED INTRODUCTION

Keenan Crane • CMU 15-458/858



Integration of Differential k -Forms

Integration and Differentiation

- Two big ideas in calculus:

- differentiation

- integration

- linked by *fundamental theorem of calculus*

- Exterior calculus generalizes these ideas

- differentiation of k -forms (exterior derivative)

- integration of k -forms (measure volume)

- linked by *Stokes' theorem*

- **Goal:** integrate differential forms over meshes to get *discrete exterior calculus (DEC)*

$$\int_a^b f' dx = f(b) - f(a)$$

$$\int_M d\alpha = \int_{\partial M} \alpha$$

Review—Integration of Area

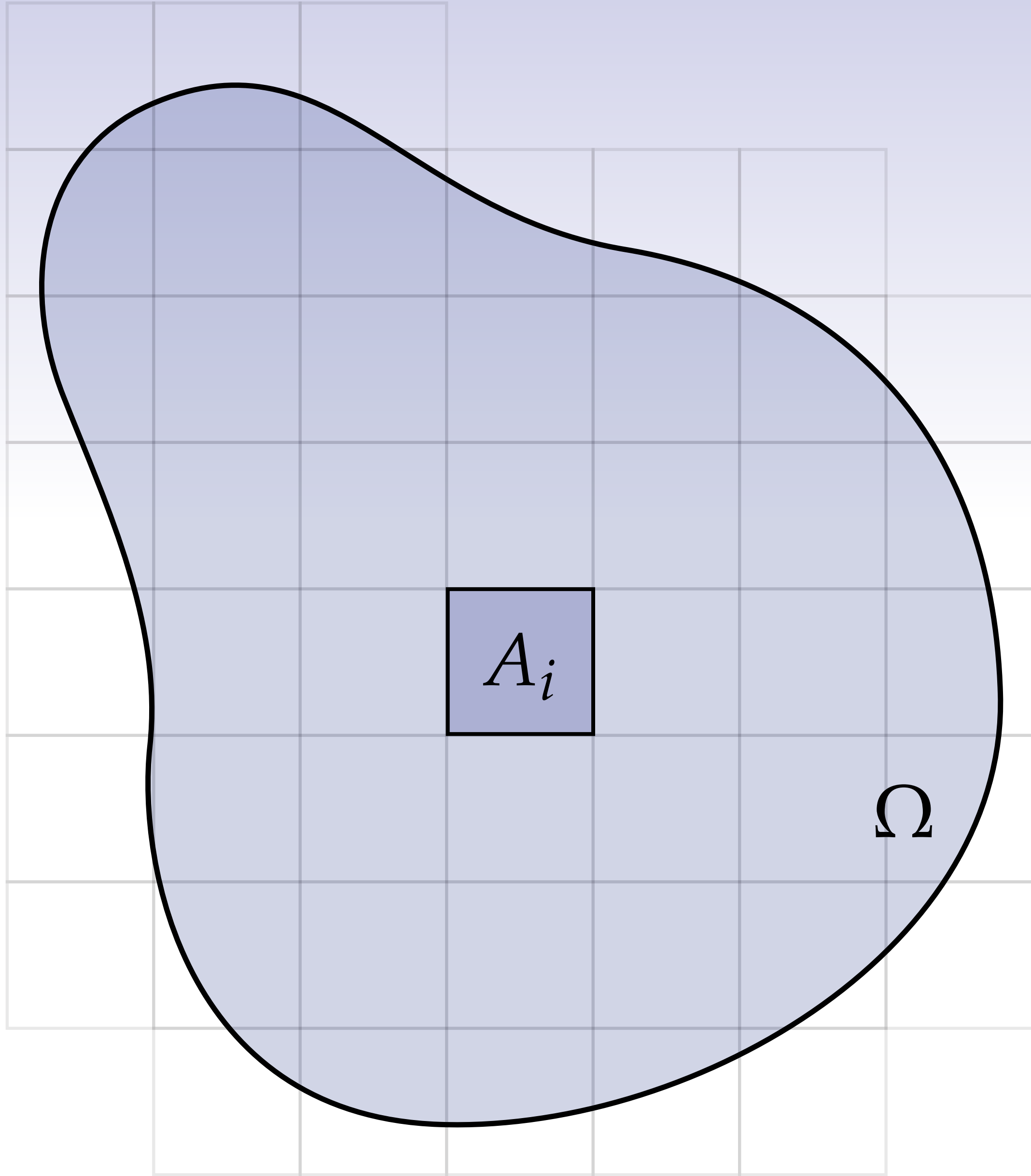

$$\sum_i A_i \implies \int_{\Omega} dA$$

Review—Integration of Scalar Functions

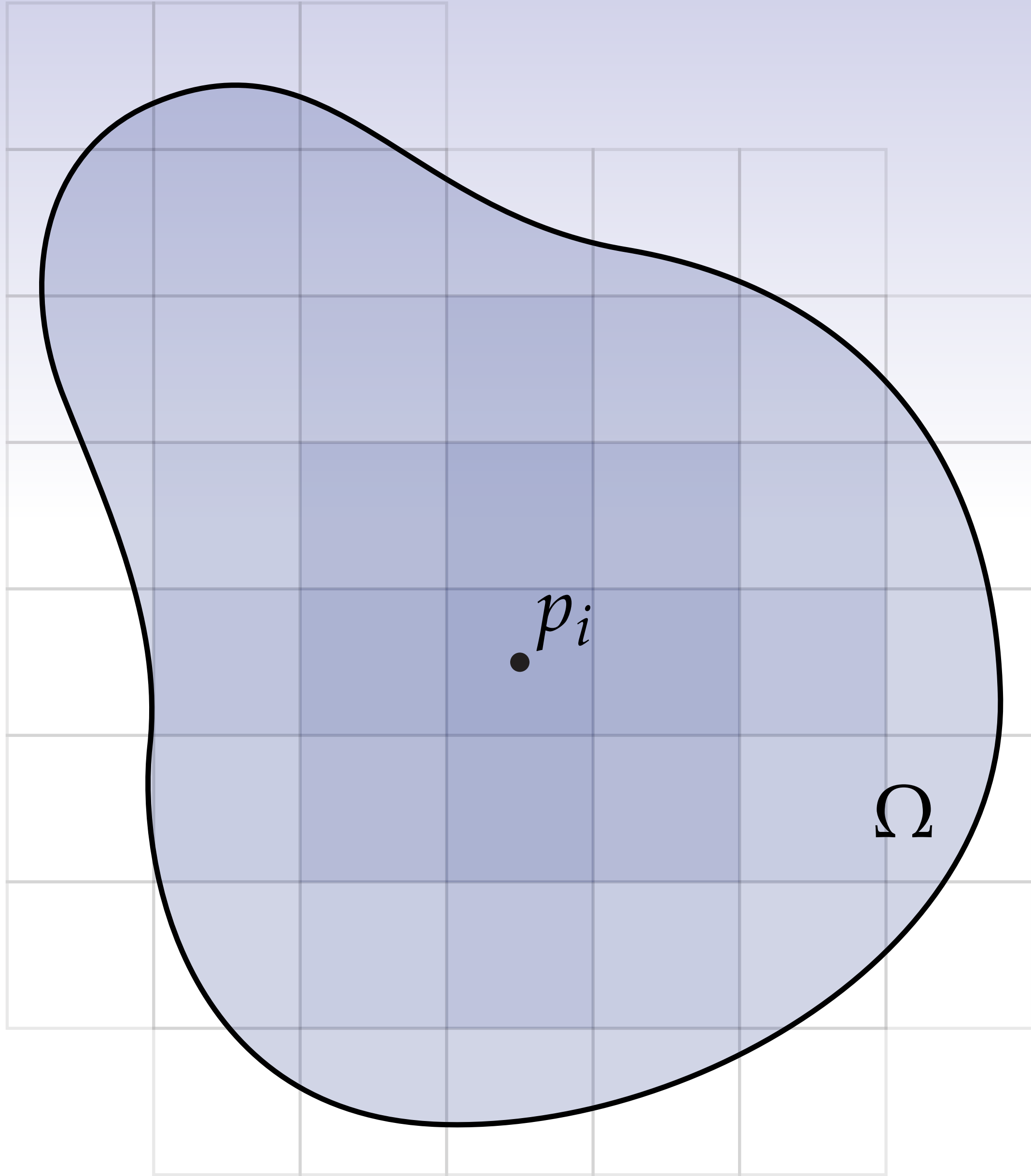

$$\phi : \Omega \rightarrow \mathbb{R}$$

$$\sum_i A_i \phi(p_i) \implies \int_{\Omega} \phi \, dA$$

Integration of a 2-Form

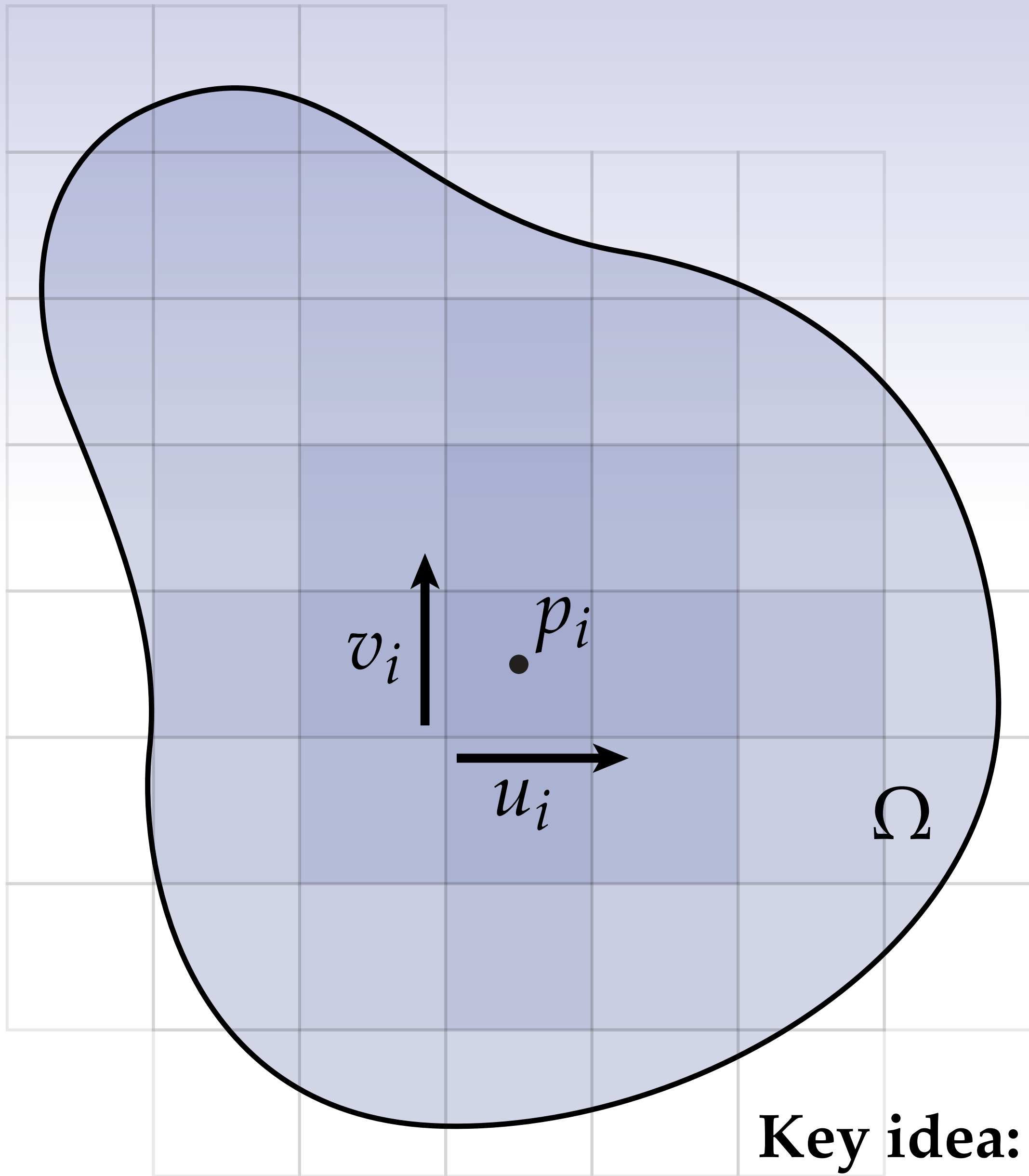

ω — differential 2-form on Ω

$$\sum_i \omega_{p_i}(u_i, v_i) \implies \int_{\Omega} \omega$$

Key idea: integration *always* involves differential forms!

Integration of Differential 2-forms — Example

- Consider a differential 2-form on the unit square in the plane:

$$\begin{aligned}\int_{\Omega} \omega &= \int_{\Omega} (x + xy) dx \wedge dy \\ &= \int_0^1 \int_0^1 (x + xy) dx \wedge dy \\ &= \dots = \frac{3}{4}\end{aligned}$$

$$\omega := (x + xy) dx \wedge dy$$

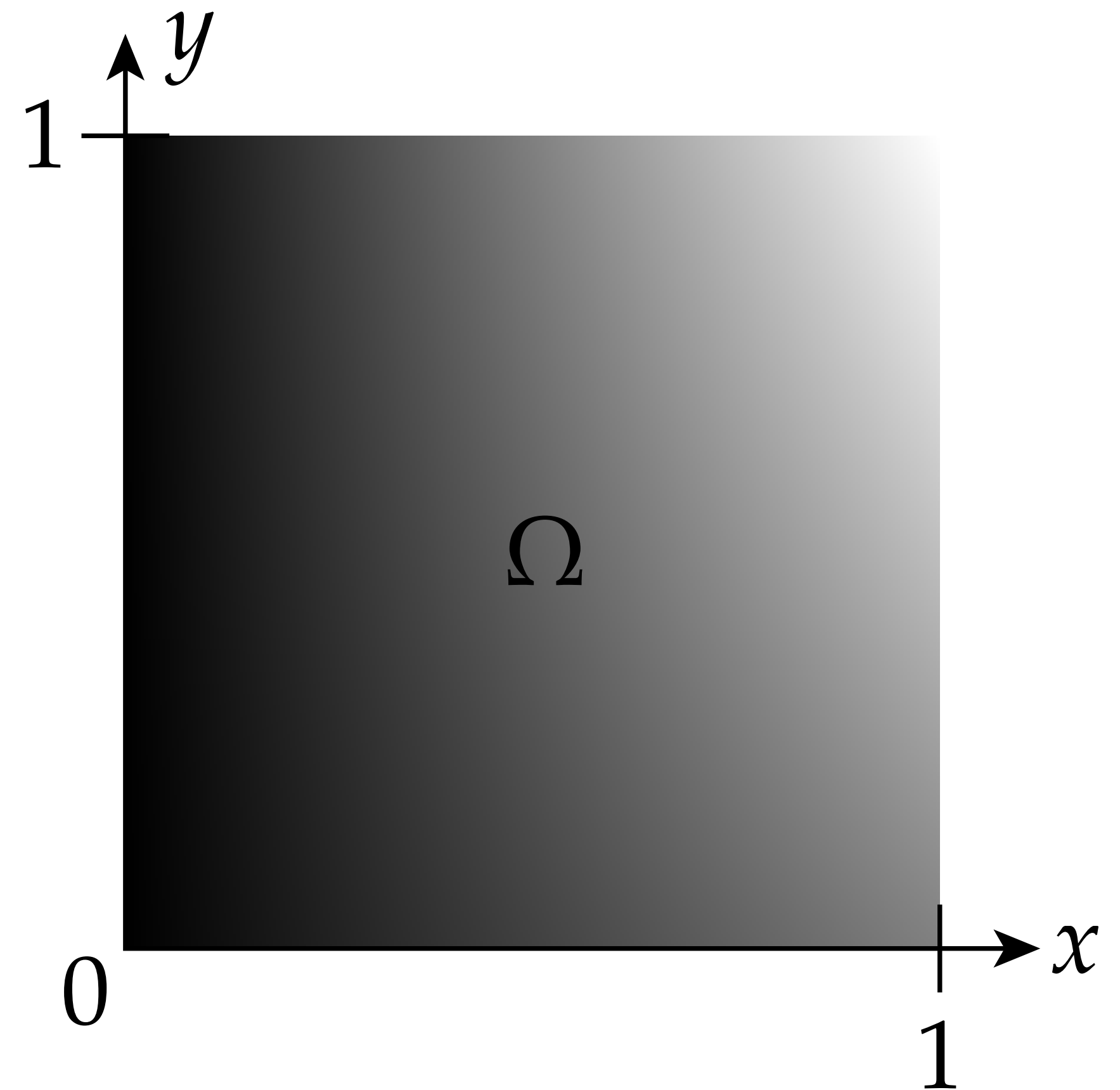

- In this case, no different from usual “double integration” of a scalar function.

Integration on Curves

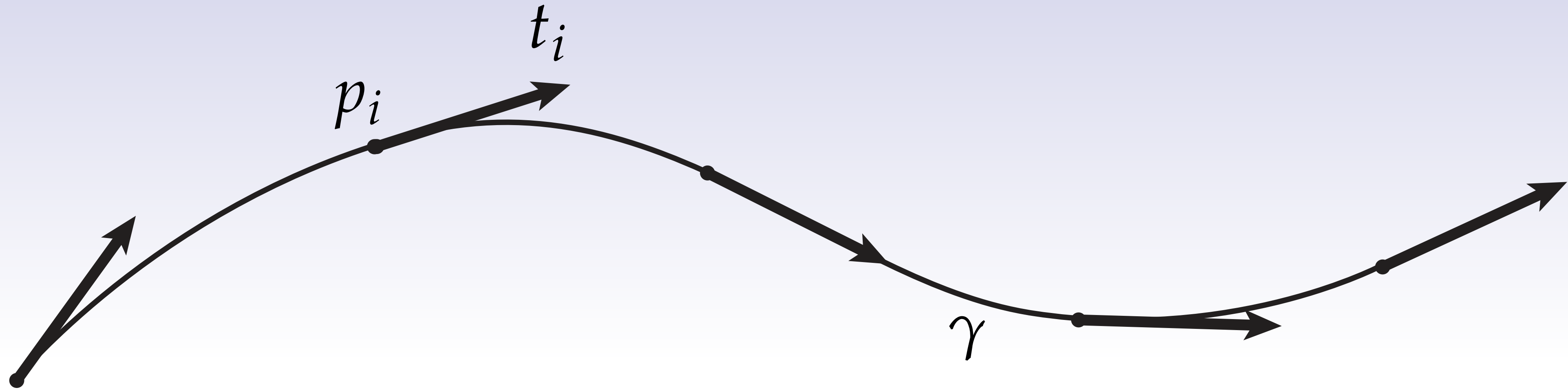

$$\int_{\gamma} \alpha \approx \sum_i \alpha_{p_i}(t_i)$$

Integration on Curves

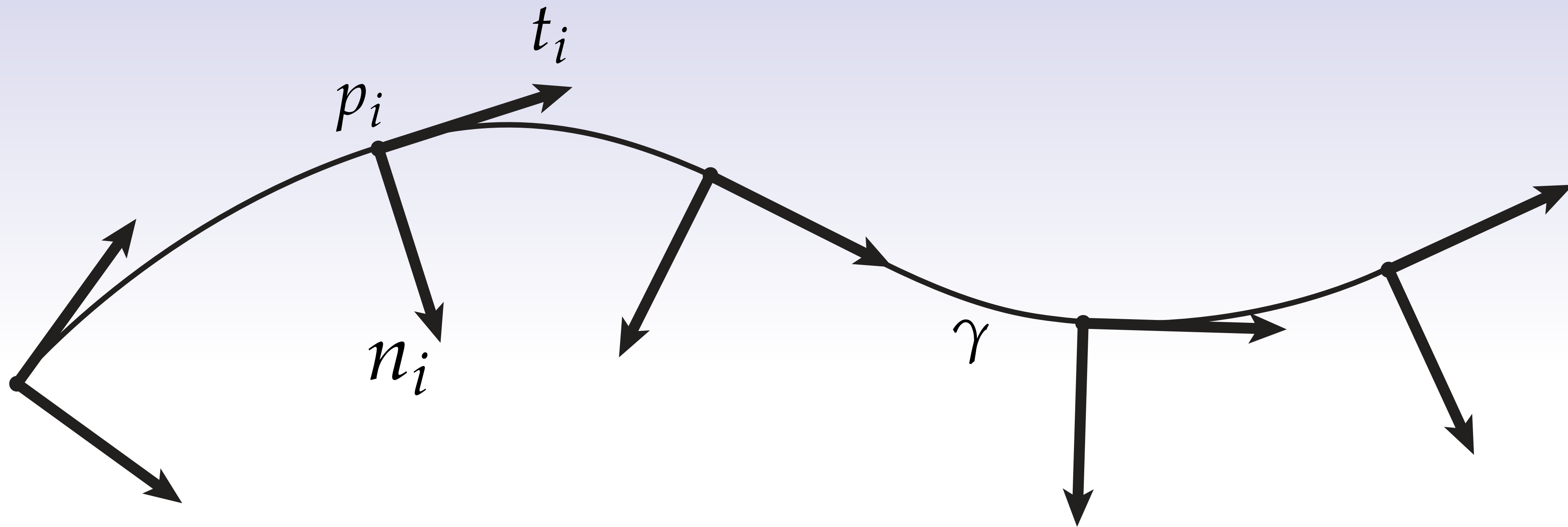

$$\int_{\gamma} \star \alpha \approx \sum_i \star \alpha_{p_i}(t_i) = \sum_i \alpha_{p_i}(n_i)$$

Integration on Curves—Example

- Now consider a 1-form in the plane, which we will integrate over the unit circle:

$$\begin{aligned}\int_{S^1} \alpha &= \int_0^{2\pi} \alpha_{\gamma(s)}(T(s)) ds = \\ &= \int_0^{2\pi} \alpha_{\gamma(s)}\left(-\sin(s) \frac{\partial}{\partial x} + \cos(s) \frac{\partial}{\partial y}\right) ds = \\ &= \int_0^{2\pi} dy \left(-\sin(s) \frac{\partial}{\partial x} + \cos(s) \frac{\partial}{\partial y}\right) ds = \\ &= \int_0^{2\pi} \cos(s) ds = 0\end{aligned}$$

(Why does this result make sense geometrically?)

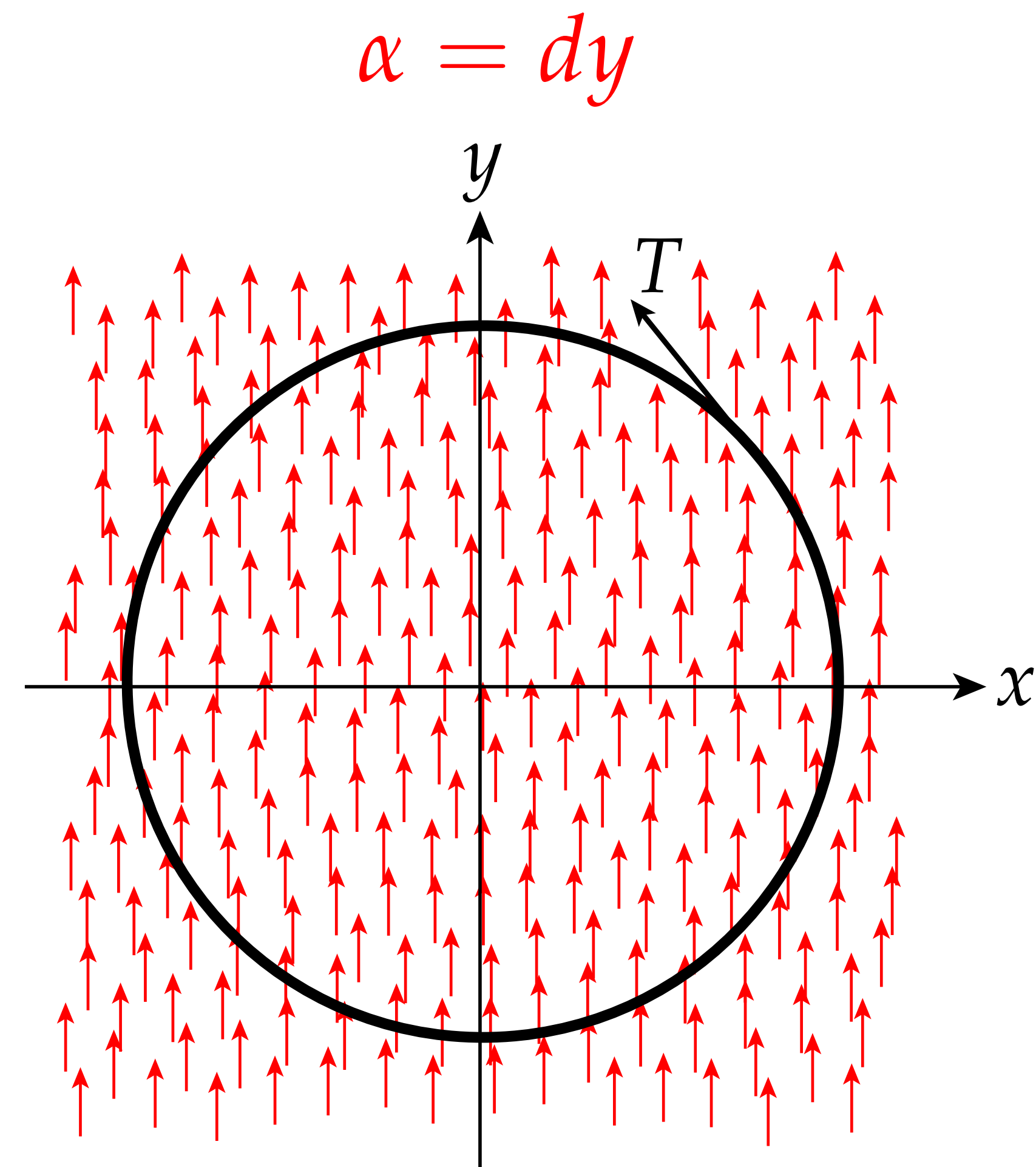

$$\gamma : [0, 2\pi) \rightarrow \mathbb{R}^2; s \mapsto (\cos(s), \sin(s))$$



Stokes' Theorem

Boundary

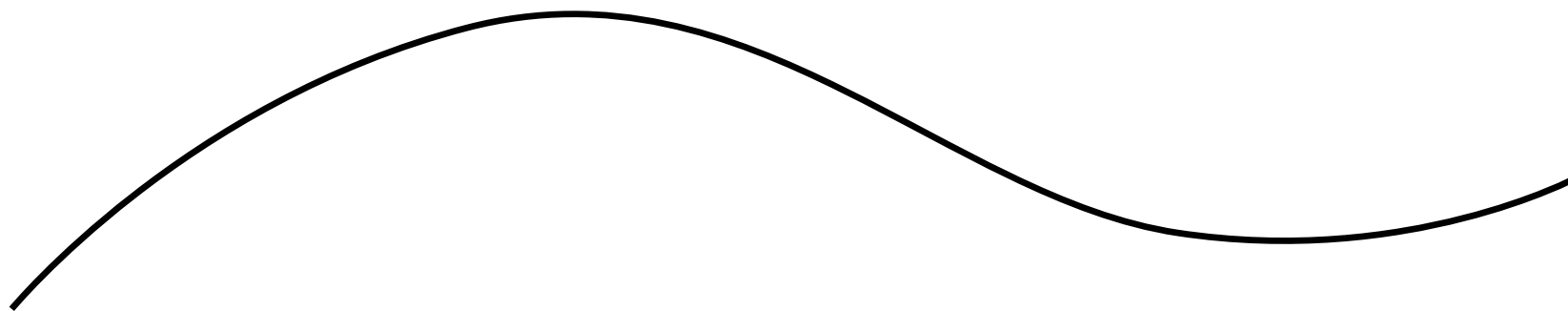
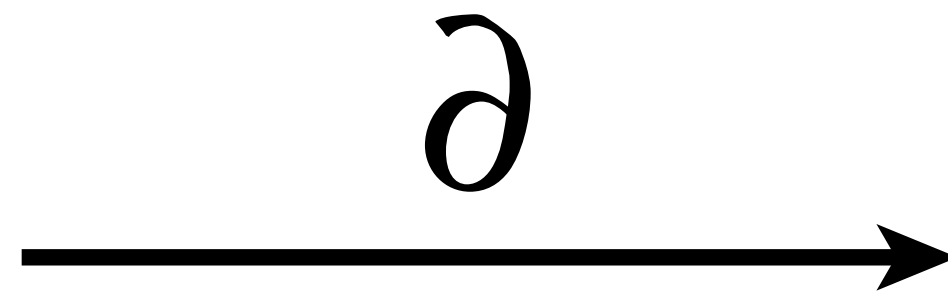
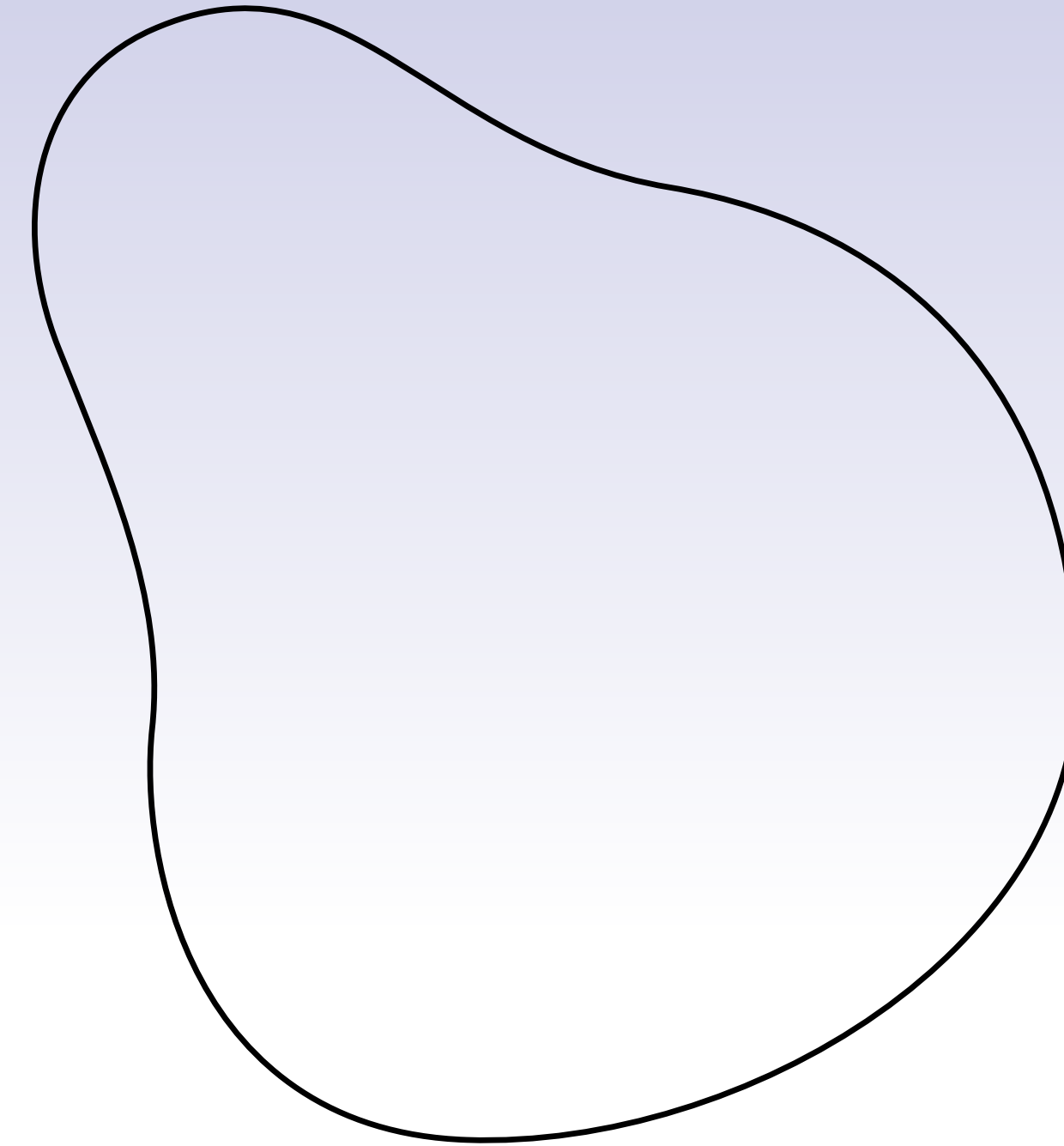
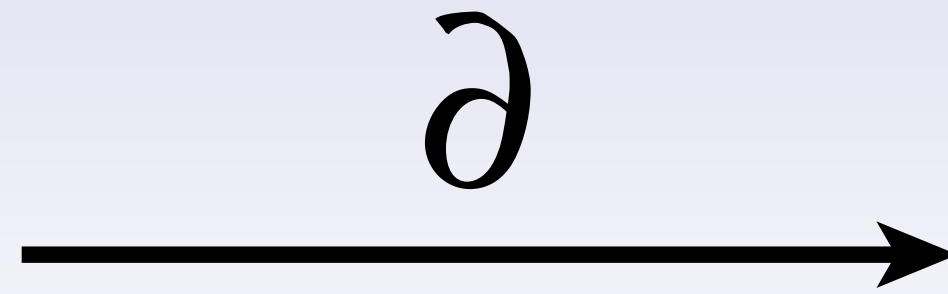
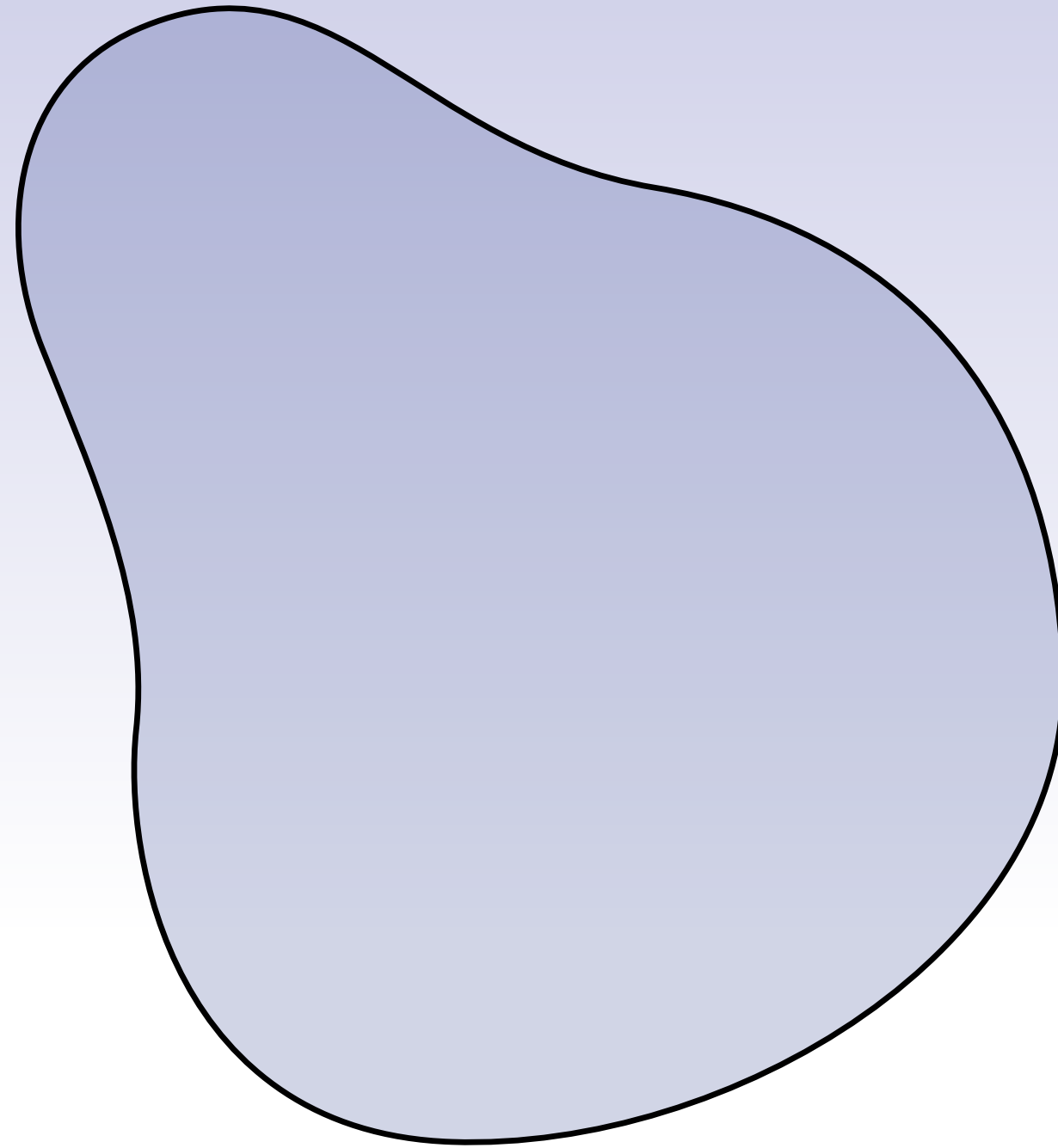

Boundary

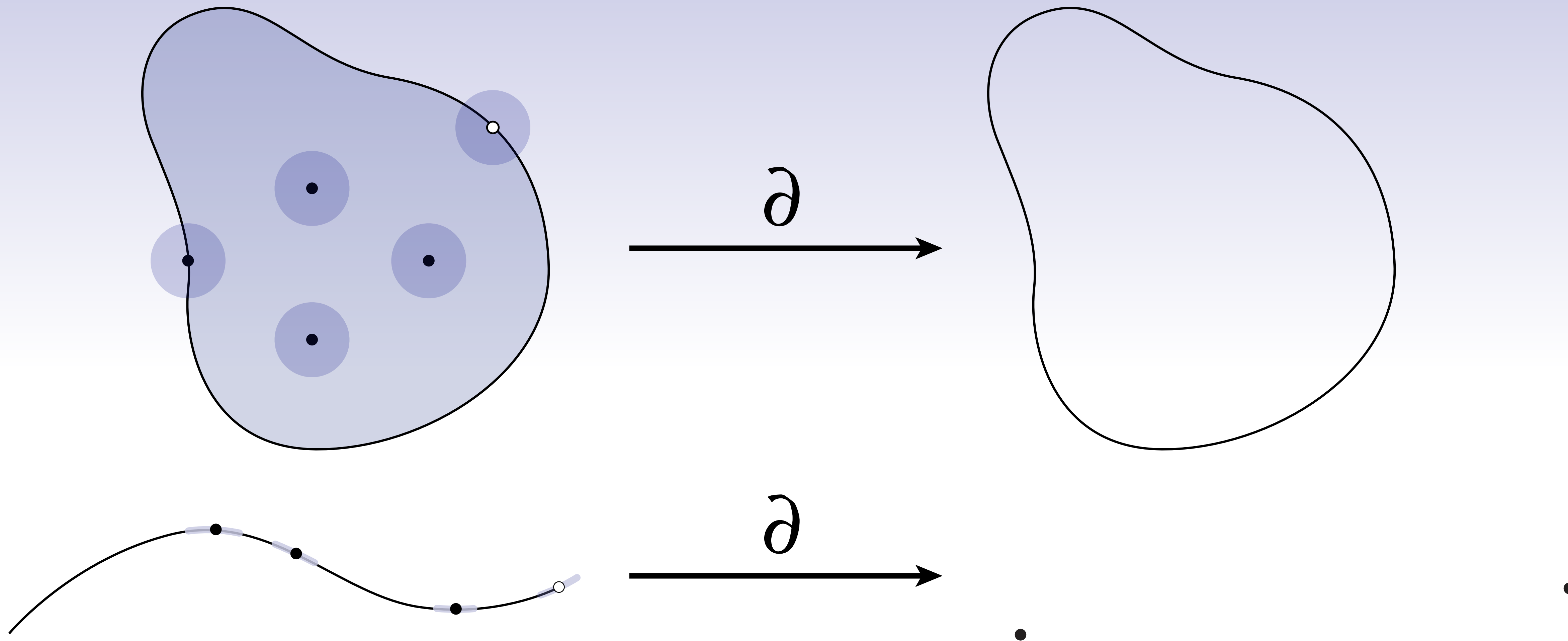

Basic idea: at an interior point p of a k -dimensional set the intersection of an open ball around p with the set looks like* an open k -ball; at a boundary point it doesn't.

*...is homeomorphic to, in the subspace topology.

Boundary of a Boundary

Q: Which points are in the boundary of the boundary?

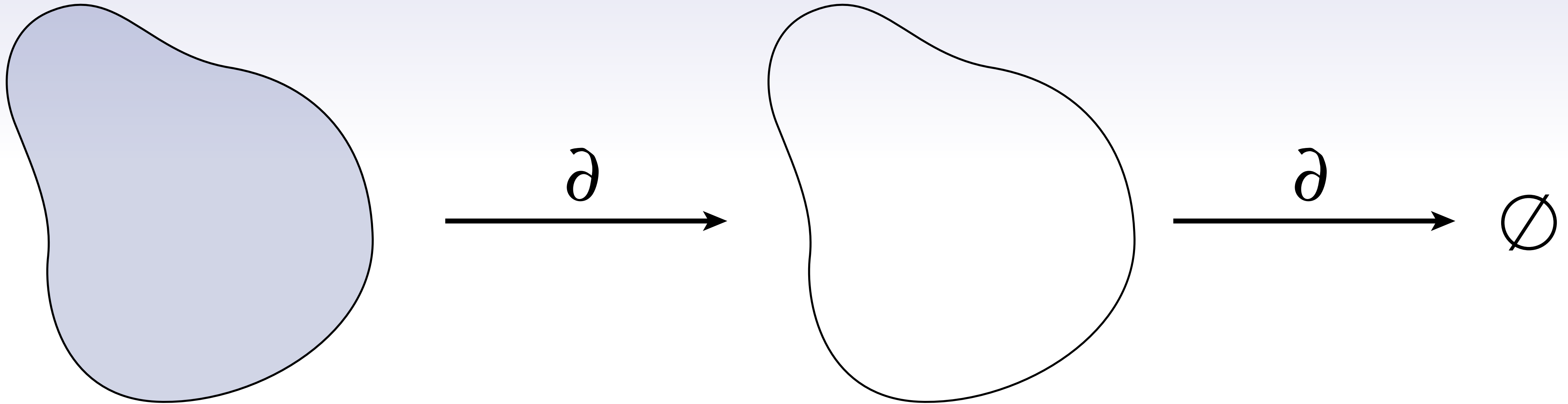

A: No points! Boundary of a boundary is always *empty*.

Boundary of a Boundary

Q: Which points are in the boundary of the boundary?

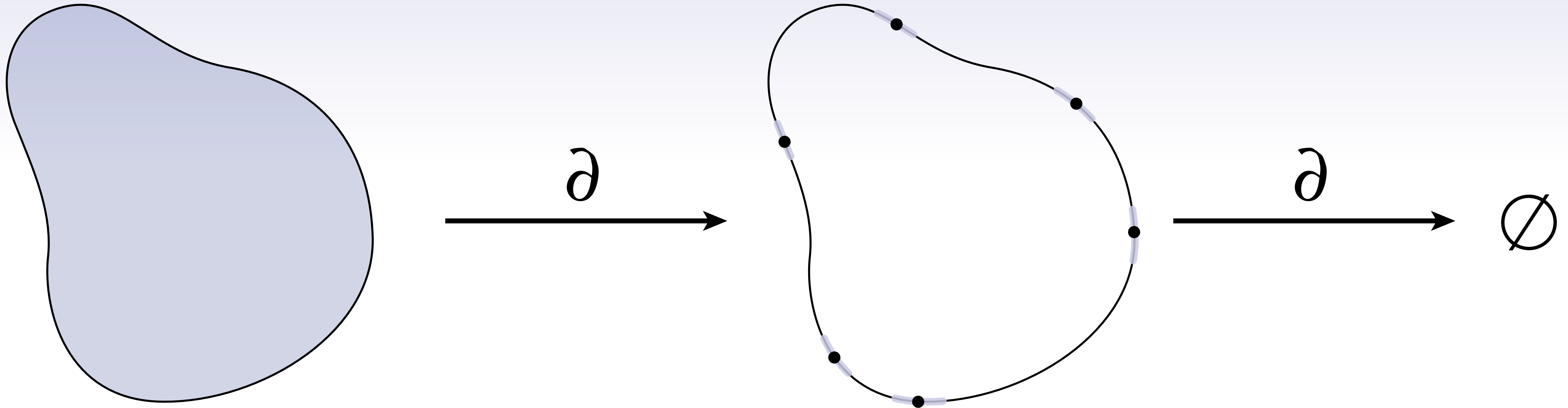

A: No points! Boundary of a boundary is always *empty*.

Review: Fundamental Theorem of Calculus

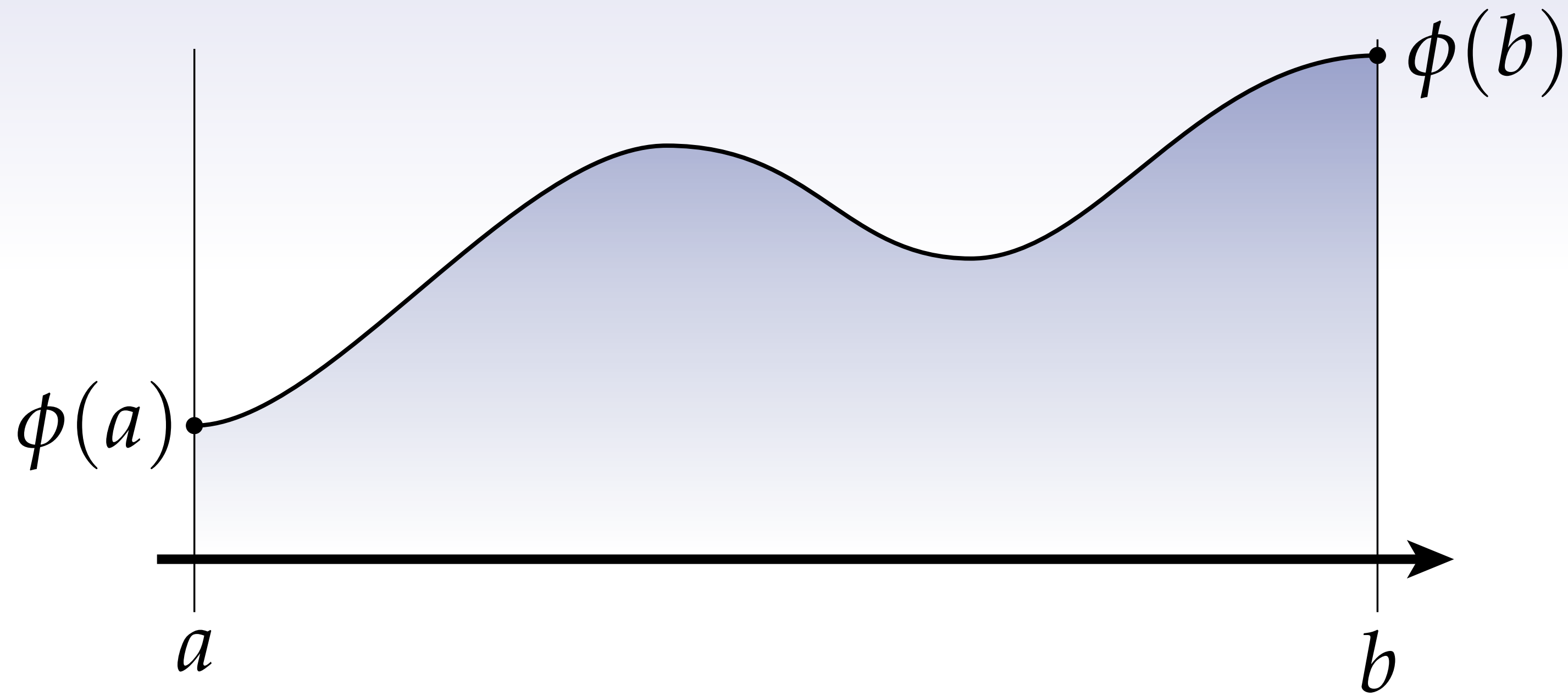

$$\int_a^b \frac{\partial \phi}{\partial x} dx = \phi(b) - \phi(a)$$

Stokes' Theorem

$$\int_{\Omega} d\alpha = \int_{\partial\Omega} \alpha$$

Analogy: fundamental theorem of calculus

Example: Divergence Theorem

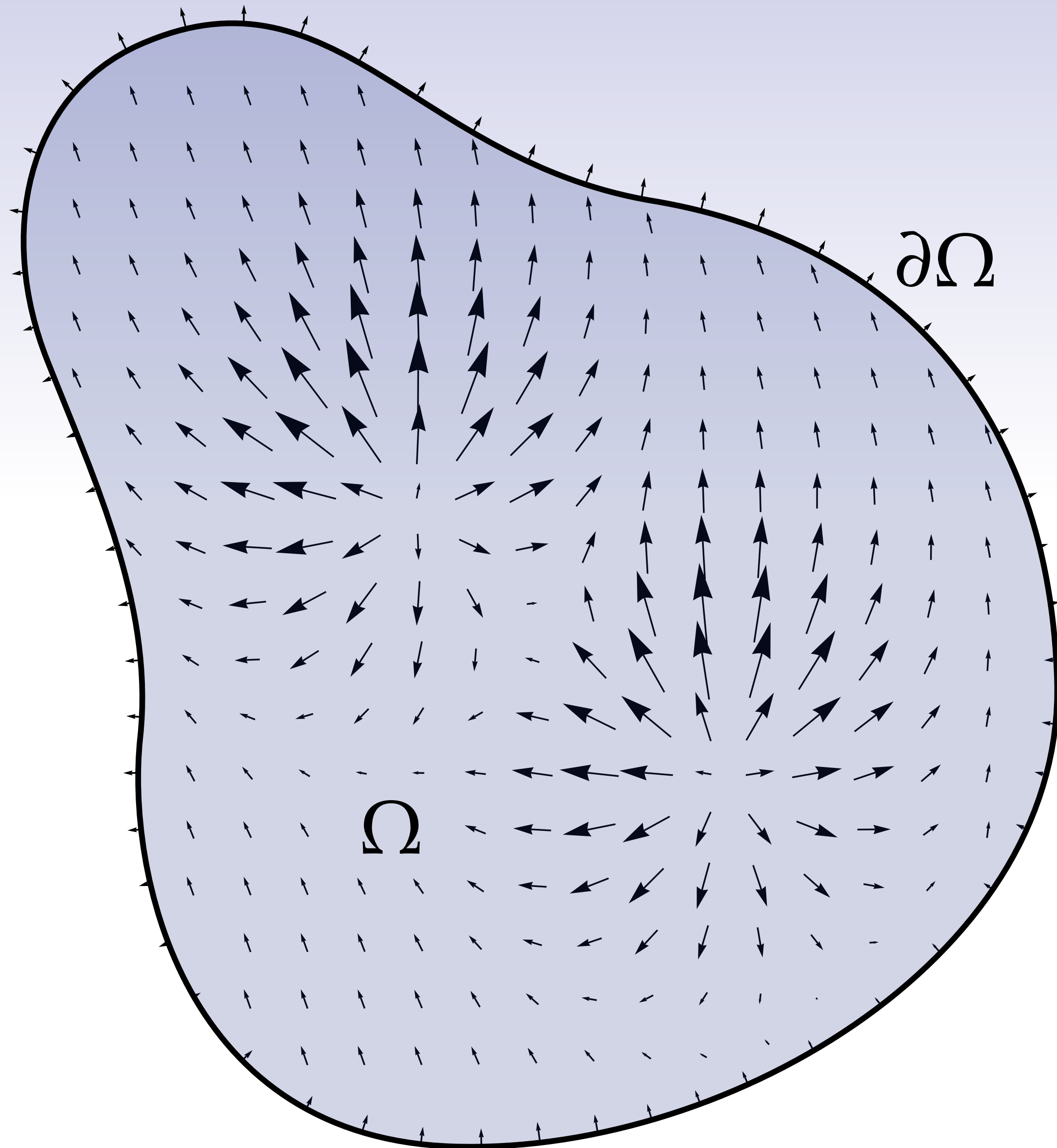

$$\int_{\Omega} \nabla \cdot X \, dA = \int_{\partial\Omega} n \cdot X \, d\ell$$

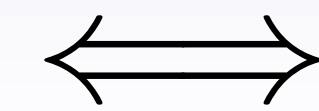

$$\int_{\Omega} d \star \alpha = \int_{\partial\Omega} \star \alpha$$

What goes in, must come out!

Example: Green's Theorem

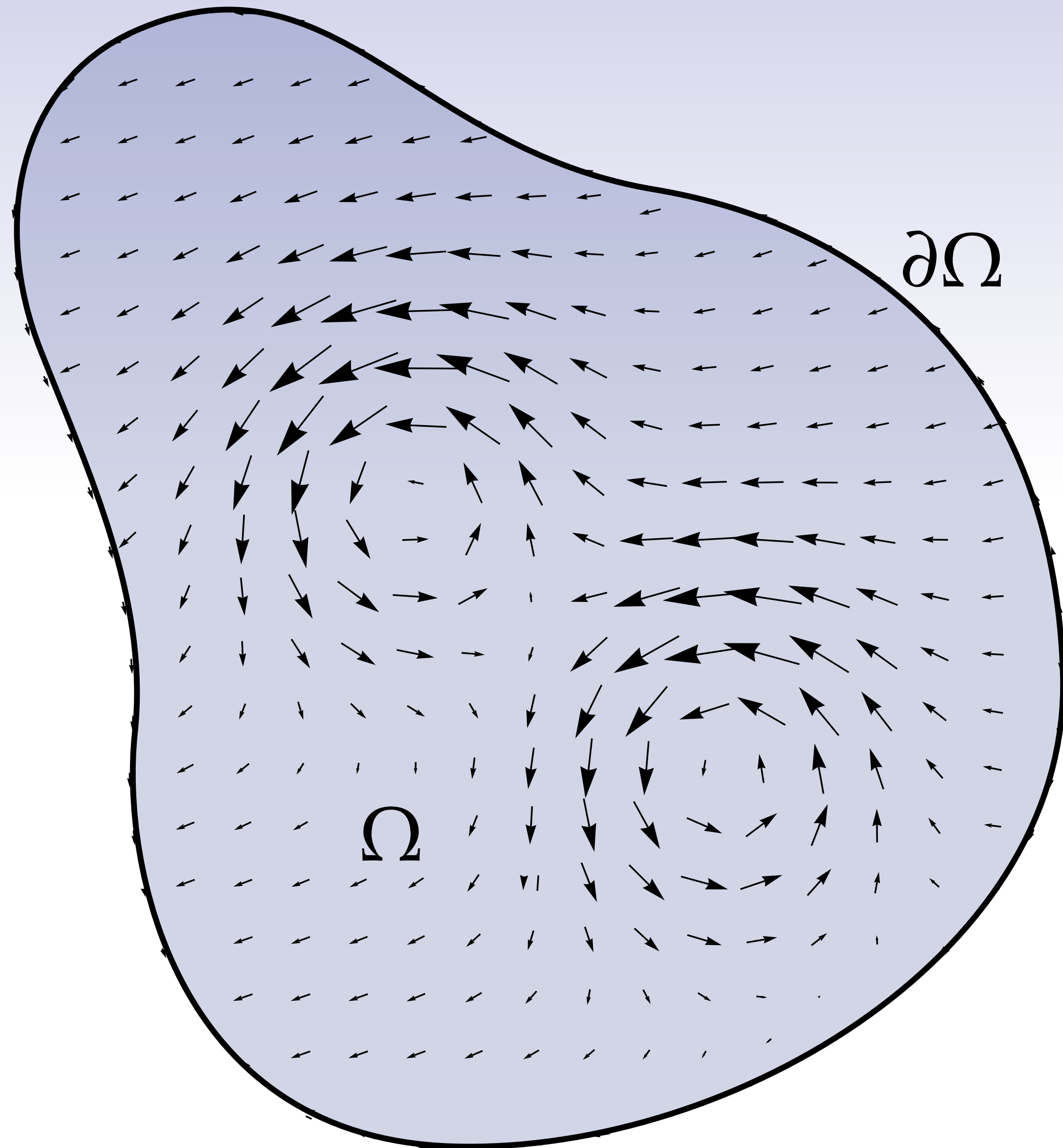

$$\int_{\Omega} \nabla \times X \, dA = \int_{\partial\Omega} t \cdot X \, d\ell$$

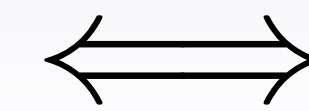

$$\int_{\Omega} d\alpha = \int_{\partial\Omega} \alpha$$

What goes around comes around!

Stokes' Theorem

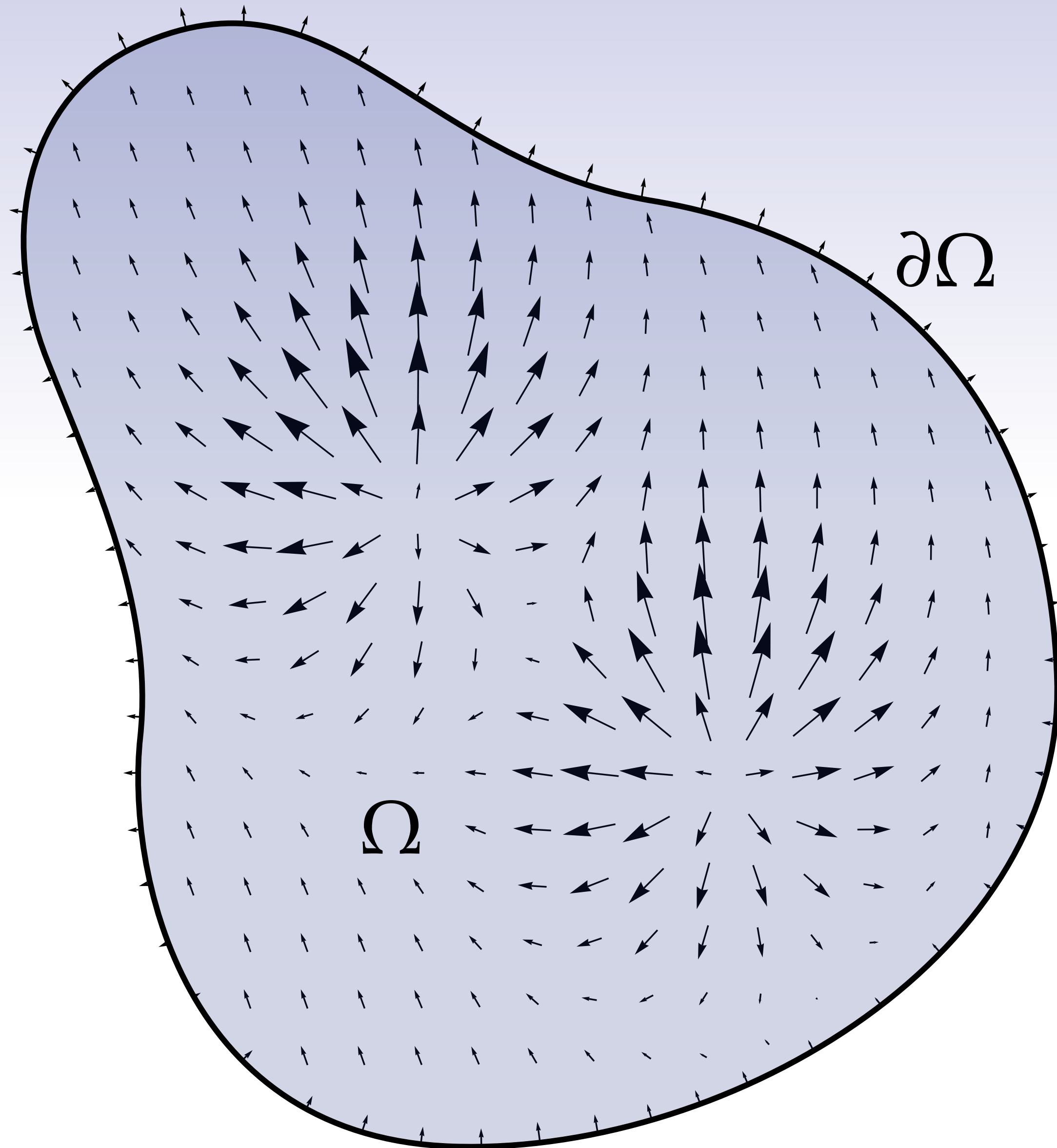

$$\int_{\Omega} d\alpha = \int_{\partial\Omega} \alpha$$

“The change we see on the outside is purely a function of the change within.”

—Zen koan

Fundamental Theorem of Calculus & Stokes'

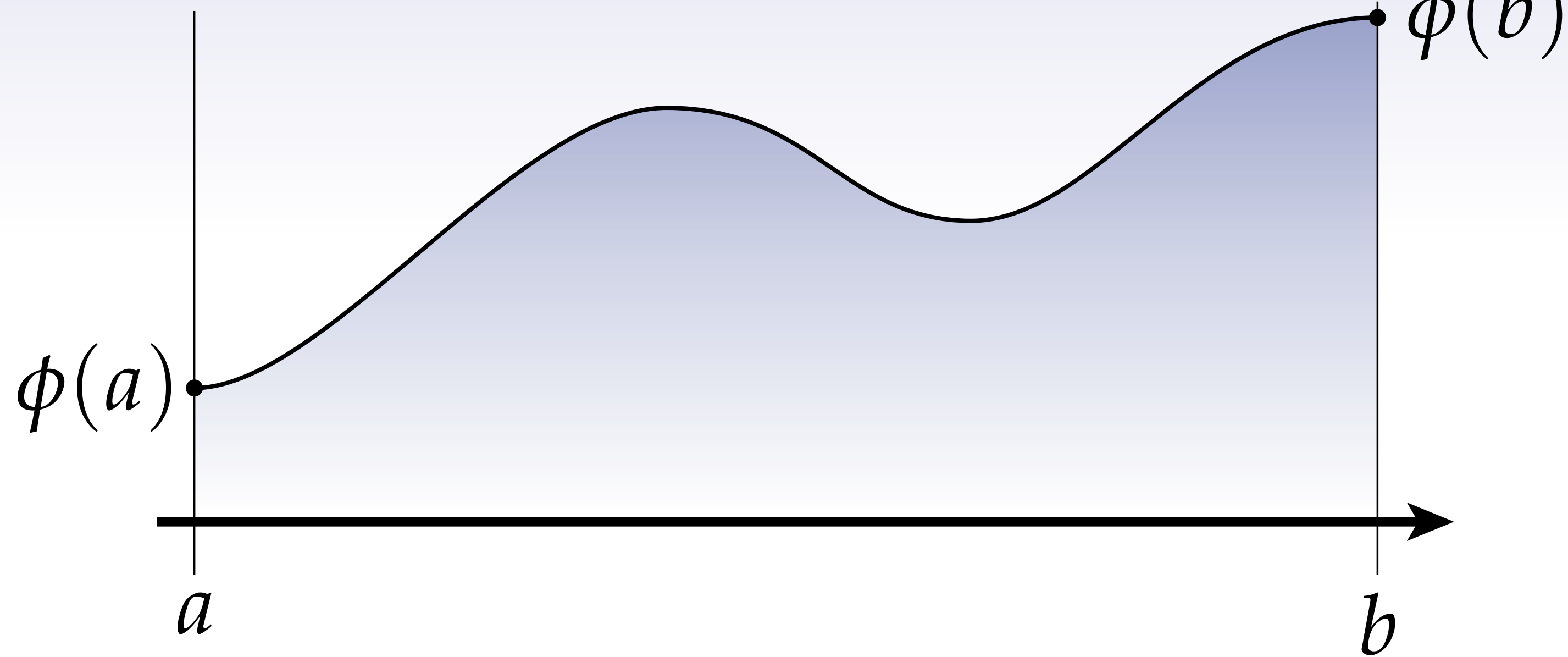

$$\int_a^b \frac{\partial \phi}{\partial x} dx = \phi(b) - \phi(a)$$

\iff

$$\int_{[a,b]} d\phi = \int_{\partial[a,b]} \phi$$

Why is $d \circ d = 0$?

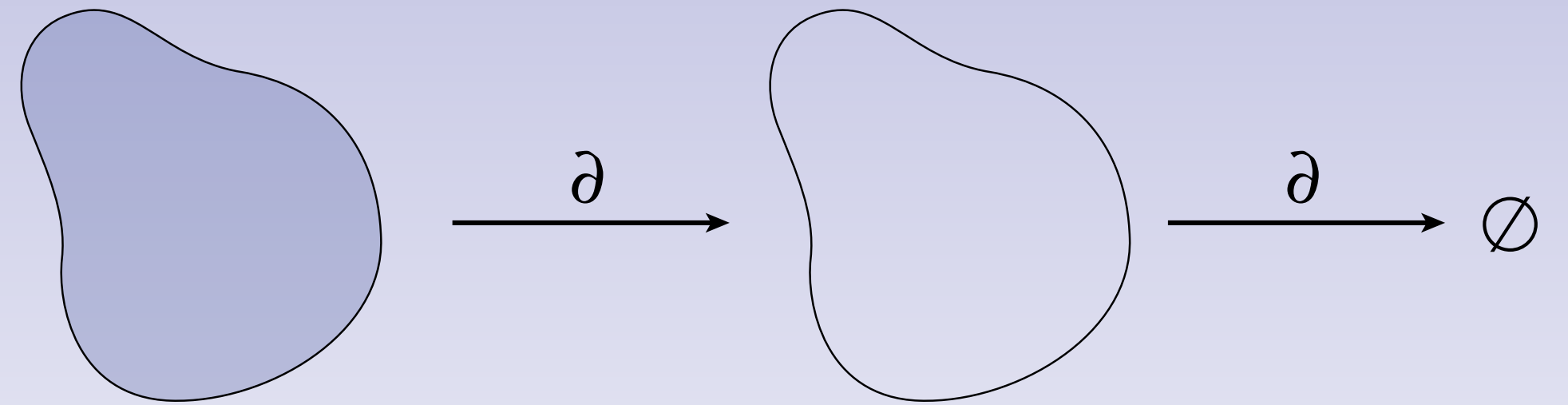

$$\int_{\Omega} dd\phi = \int_{\partial\Omega} d\phi = \int_{\underbrace{\partial\partial\Omega}_{\emptyset}} \phi = 0$$

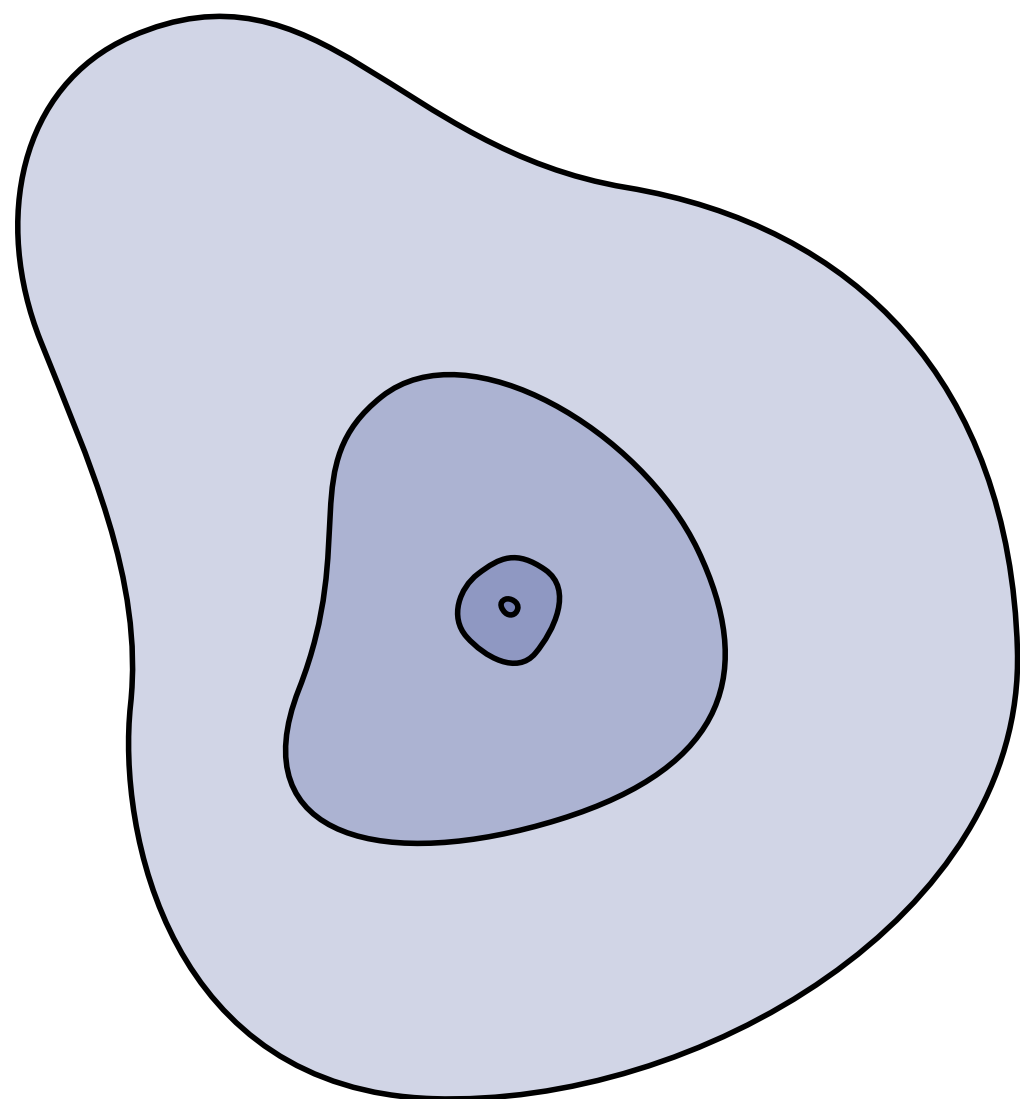

...for *any* Ω (no matter how small!)

Why is $d \circ d = 0$?

Unique *linear* map $d : \Omega^k \rightarrow \Omega^{k+1}$ such that

“behaves like gradient for functions”

differential $d\phi = \frac{\partial\phi}{\partial x^1} dx^1 + \dots + \frac{\partial\phi}{\partial x^n} dx^n$

product rule $d(\alpha \wedge \beta) = d\alpha \wedge \beta + (-1)^k \alpha \wedge d\beta$

~~exactness $d \circ d = 0$~~

Stokes' theorem $\int_{\Omega} d\alpha = \int_{\partial\Omega} \alpha$

what goes in, must come out!

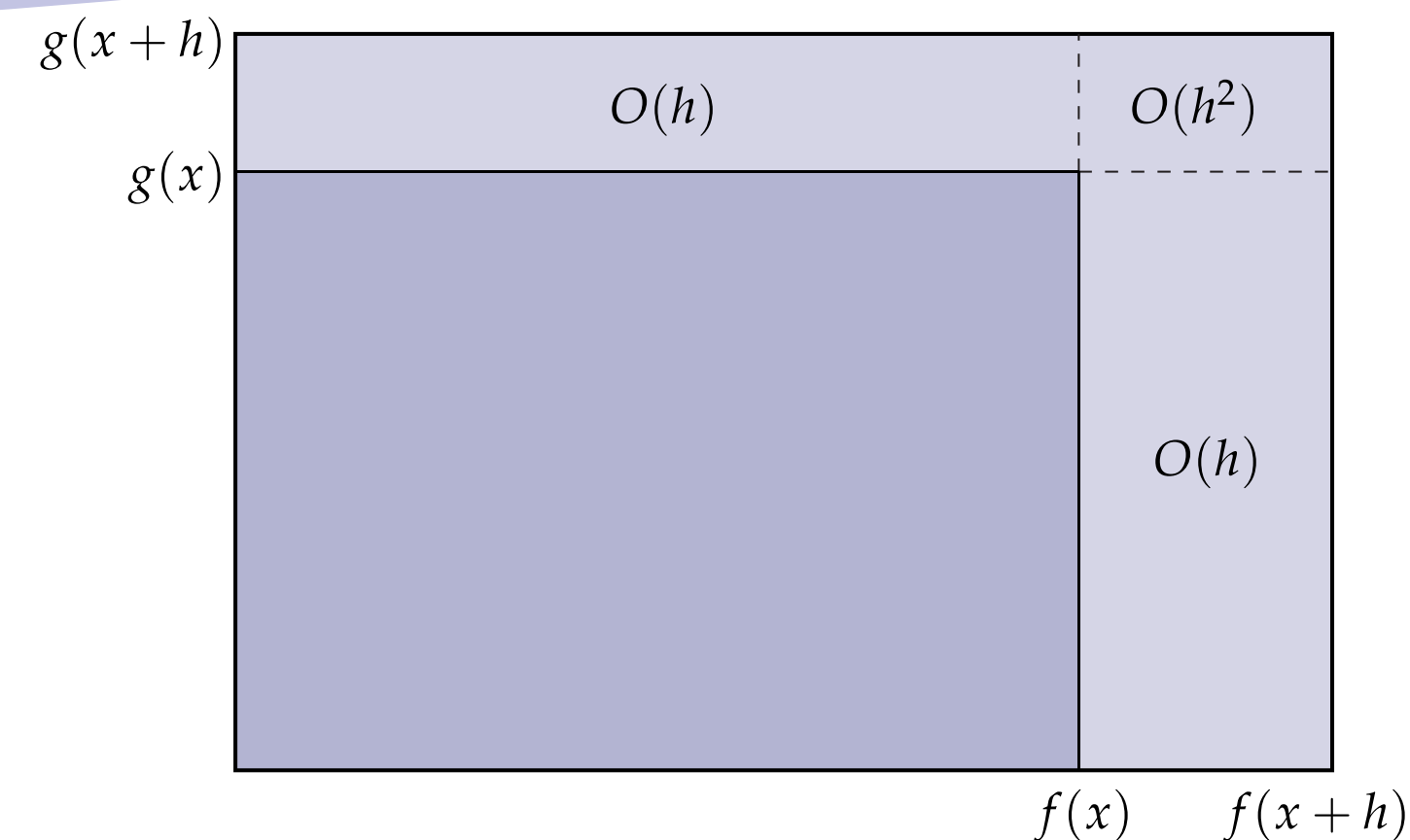

Integration & Stokes' Theorem - Summary

- Integration
 - break domain into small pieces
 - measure each piece with k -form
- Stokes' theorem
 - convert region integral to boundary integral
 - super useful—lets us “skip” a derivative
 - special cases: divergence theorem, Green's theorem, fundamental theorem of calculus, Cauchy's integral theorem... and *many more!*
 - Gets used *over and over* again in geometric computing
 - finite element methods, boundary element methods, ...
 - discrete exterior calculus

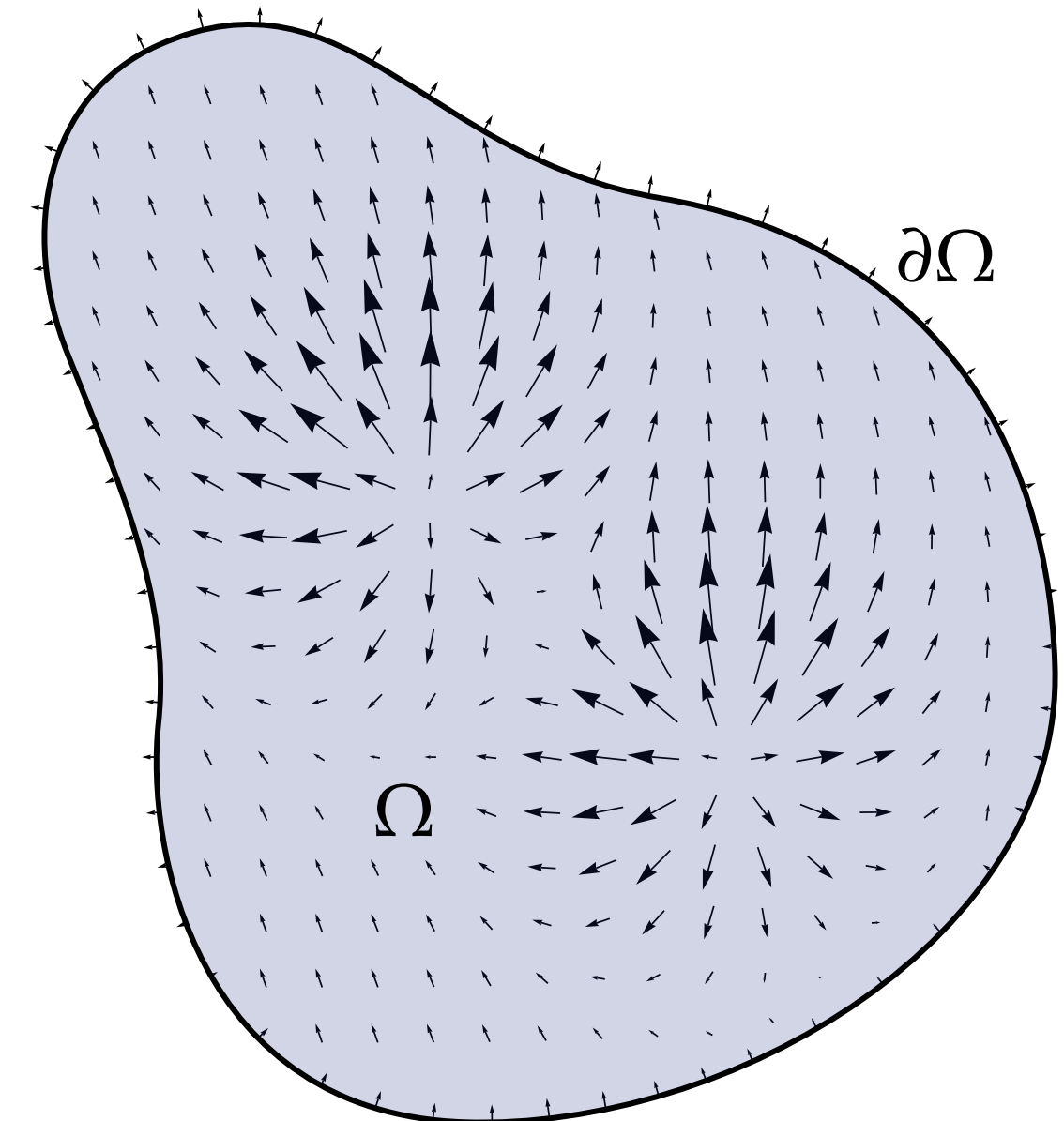
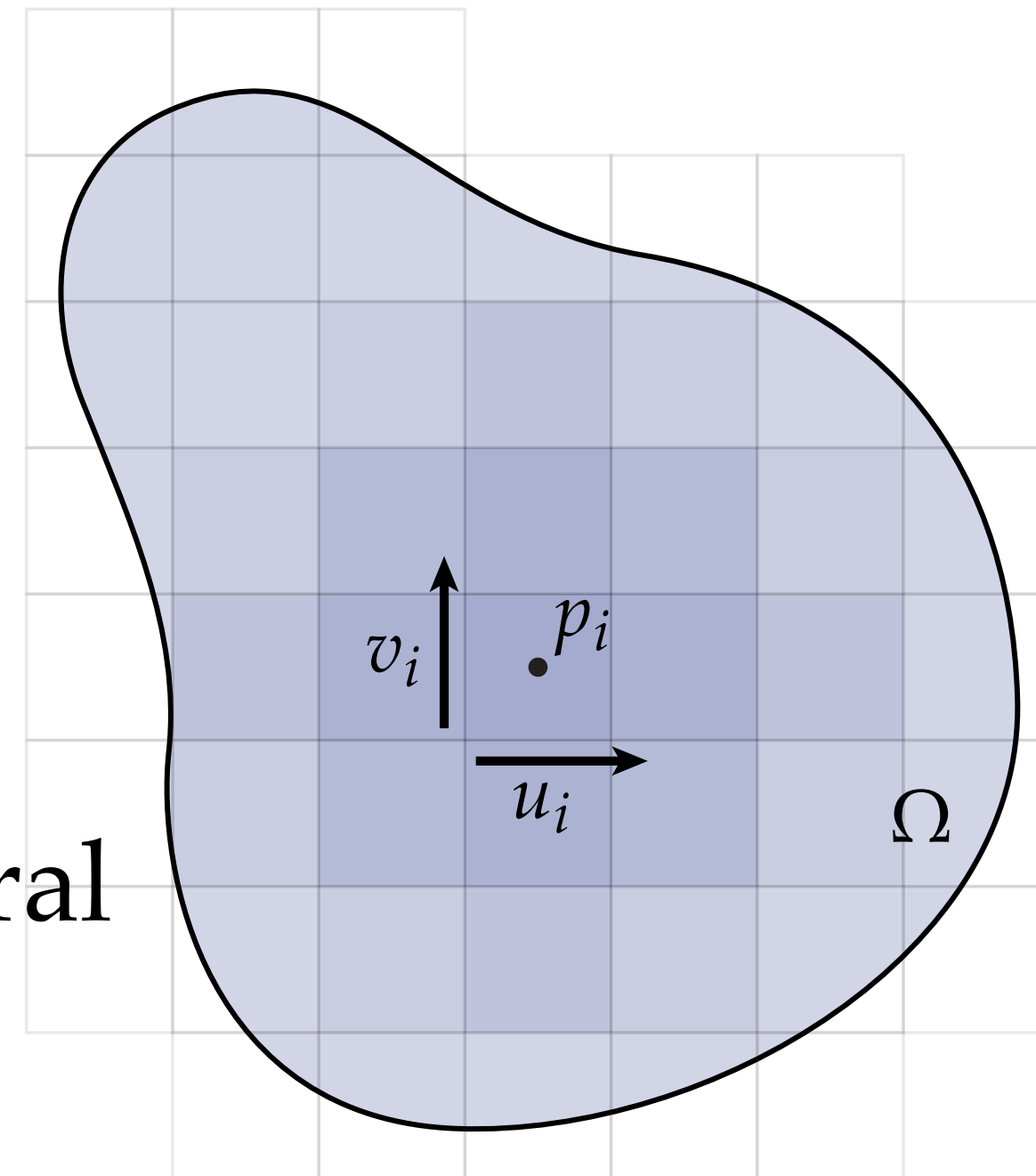

$$\int_M d\alpha = \int_{\partial M} \alpha$$



Inner Product on Differential k -Forms

Inner Product—Review

- Recall that a *vector space* V is any collection of “arrows” that can be added, scaled, ...
- **Q:** What’s an *inner product* on a vector space?
- **A:** Loosely speaking, a way to talk about lengths, angles, etc., in a vector space
- More formally, a symmetric positive-definite bilinear map:

$$\langle \cdot, \cdot \rangle : V \times V \rightarrow \mathbb{R}$$

$$\langle u, v \rangle = \langle v, u \rangle$$

$$\langle u + v, w \rangle = \langle u, w \rangle + \langle v, w \rangle$$

$$\langle au, v \rangle = a \langle u, v \rangle$$

$$\langle u, u \rangle \geq 0; \langle u, u \rangle = 0 \iff u = 0$$

for all vectors u, v, w in V and scalars a .

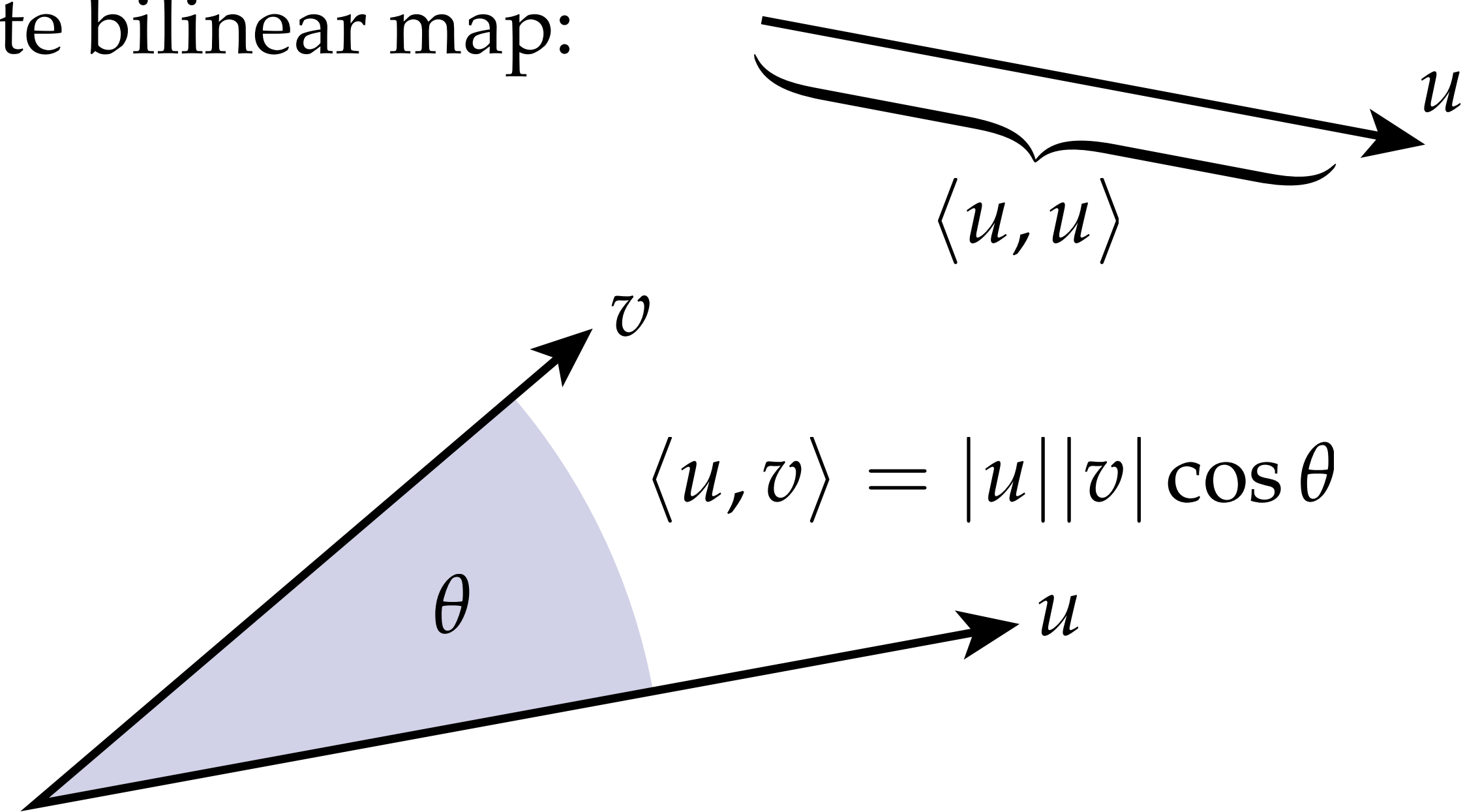

(Geometric interpretation of these rules?)

Euclidean Inner Product—Review

- Most basic inner product: inner product of two vectors in Euclidean R^n
- Just sum up the product of components:

$$\begin{aligned} u &= u^1 e_1 + \cdots + u^n e_n \\ v &= v^1 e_1 + \cdots + v^n e_n \end{aligned} \quad \langle u, v \rangle := \sum_{i=1}^n u^i v^i$$

Example.

$$u = 3e_1 + 2e_2$$

$$v = 2e_1 + 4e_2$$

$$\langle u, v \rangle = 3 \cdot 2 + 2 \cdot 4 = 14$$

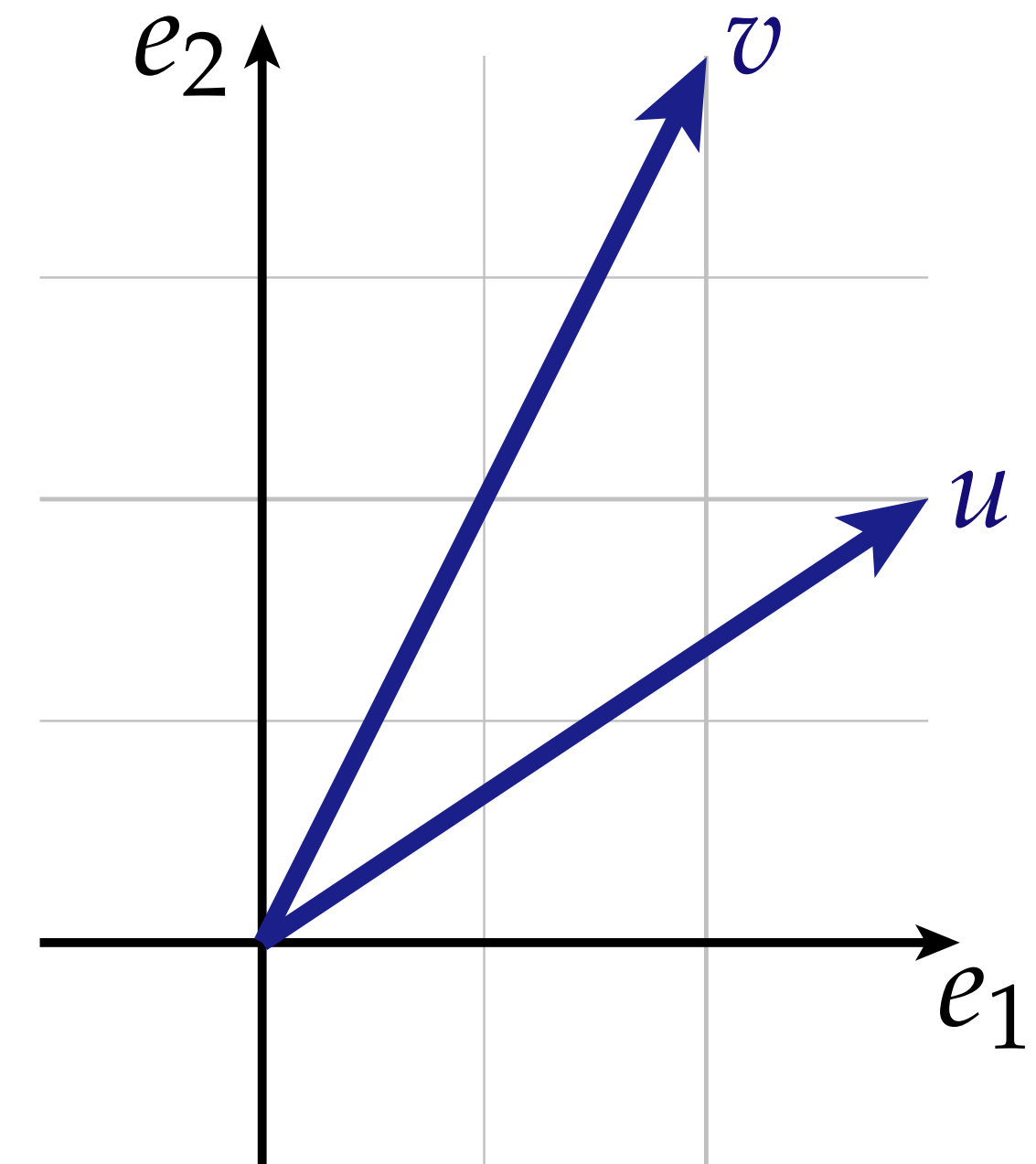

(Does this operation satisfy all the requirements of an inner product?)

L^2 Inner Product of Functions / 0-forms

- Remember that in many situations, *functions* are also vectors
- What does it mean to measure the inner product between functions?
- Want some notion of how well two functions “line up”
- One idea: mimic what we did for vectors in \mathbb{R}^n . E.g.,

$$f : [0, 1] \rightarrow \mathbb{R}$$

$$g : [0, 1] \rightarrow \mathbb{R}$$

$$\langle\langle f, g \rangle\rangle := \int_0^1 f(x)g(x)dx$$

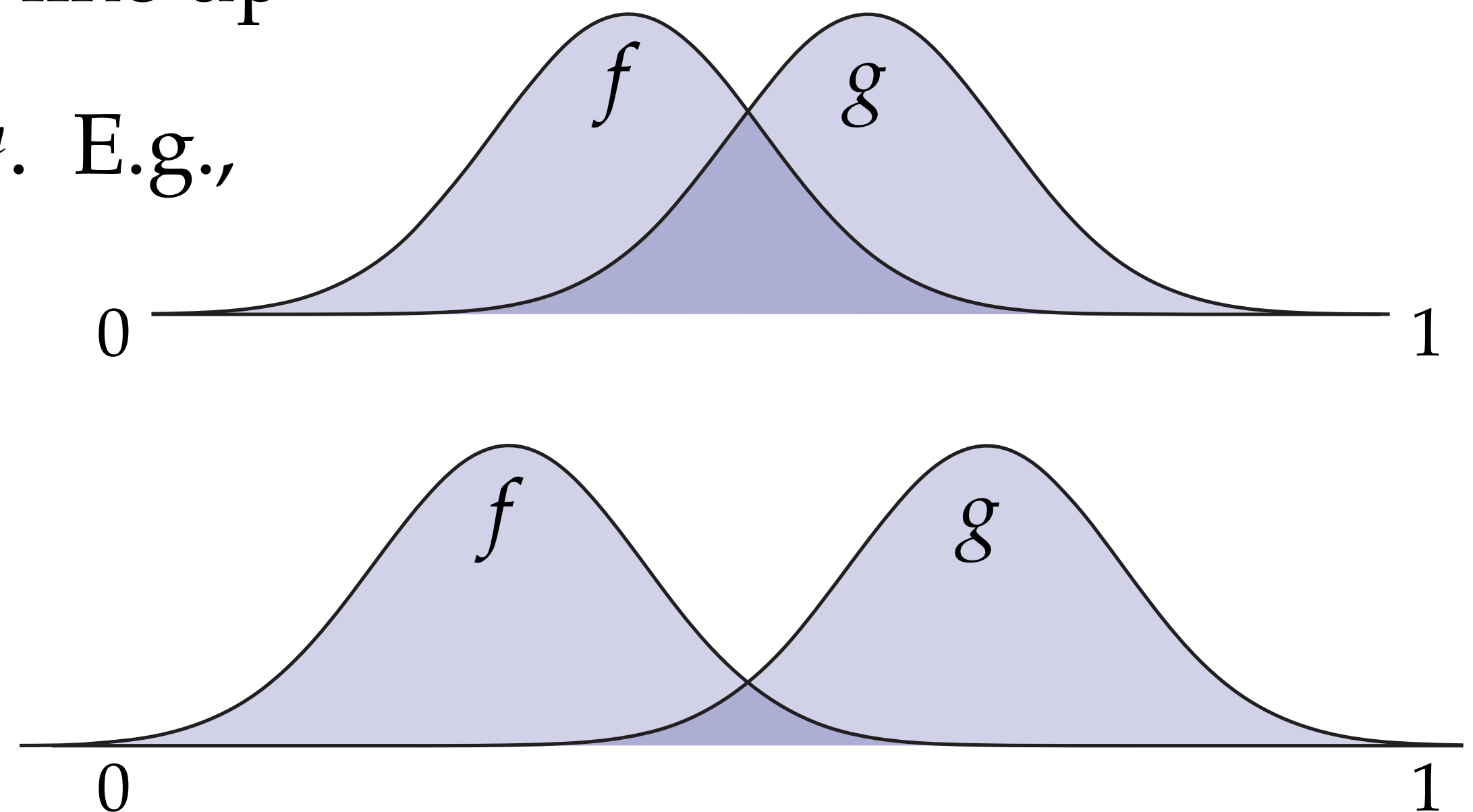

- Called the L^2 inner product. (**Note:** f and g must each be square-integrable!)
- Does this capture notion of “lining up”? Does it obey rules of inner product?

Inner Product on k -Forms

Definition. Let $\alpha, \beta \in \Omega^k$ be any two differential k -forms. Their (L^2) inner product is defined as*

$$\langle\langle \alpha, \beta \rangle\rangle := \int_{\Omega} \star \alpha \wedge \beta$$

Q: What happens when $k=0$?

A: We just get the usual L^2 inner product on functions.

Q: What's the degree (k) of the integrand? Why is that important?

A: Integrand is always an n -form, which is the only thing we can integrate in n -D!

*Some authors define the integrand as $\alpha \wedge \star \beta$; our convention is consistent with the convention that in 2D the 1-form Hodge star is a *counter*-clockwise rotation.

Inner Product of 1-Forms — Example

α

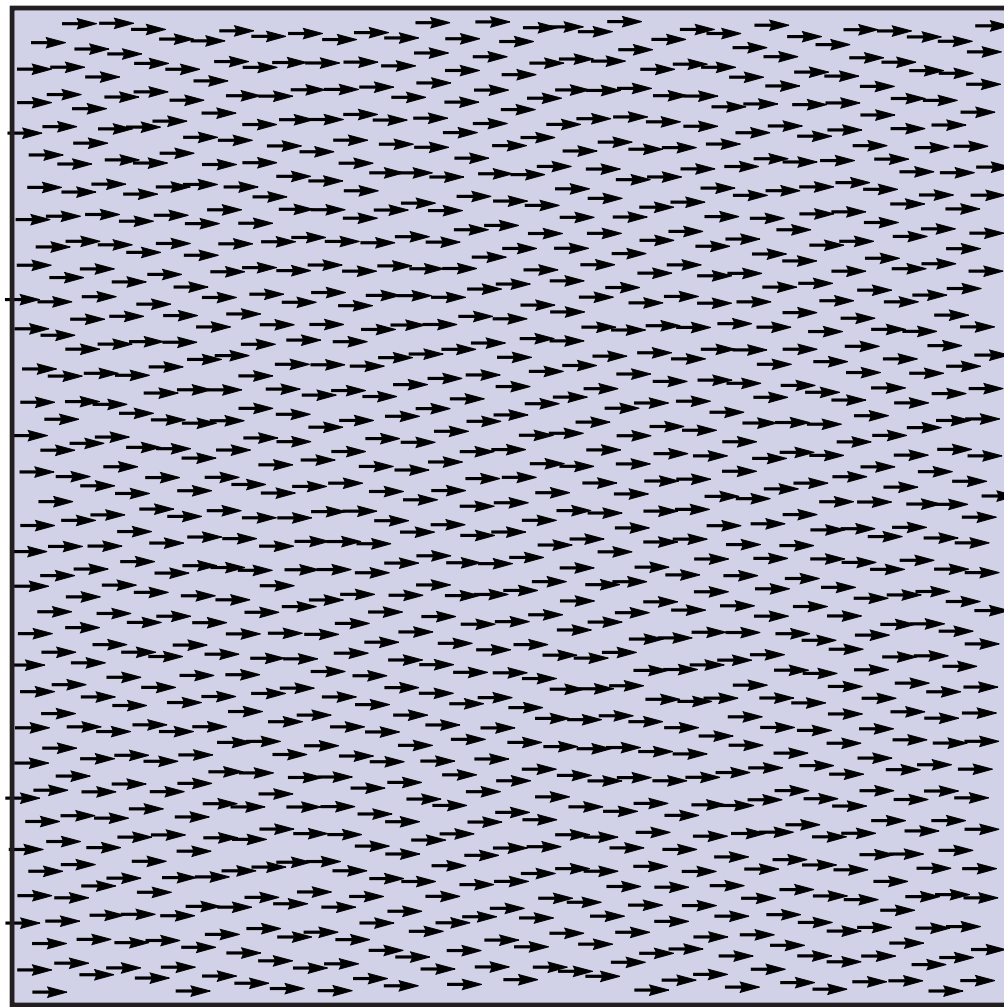

β

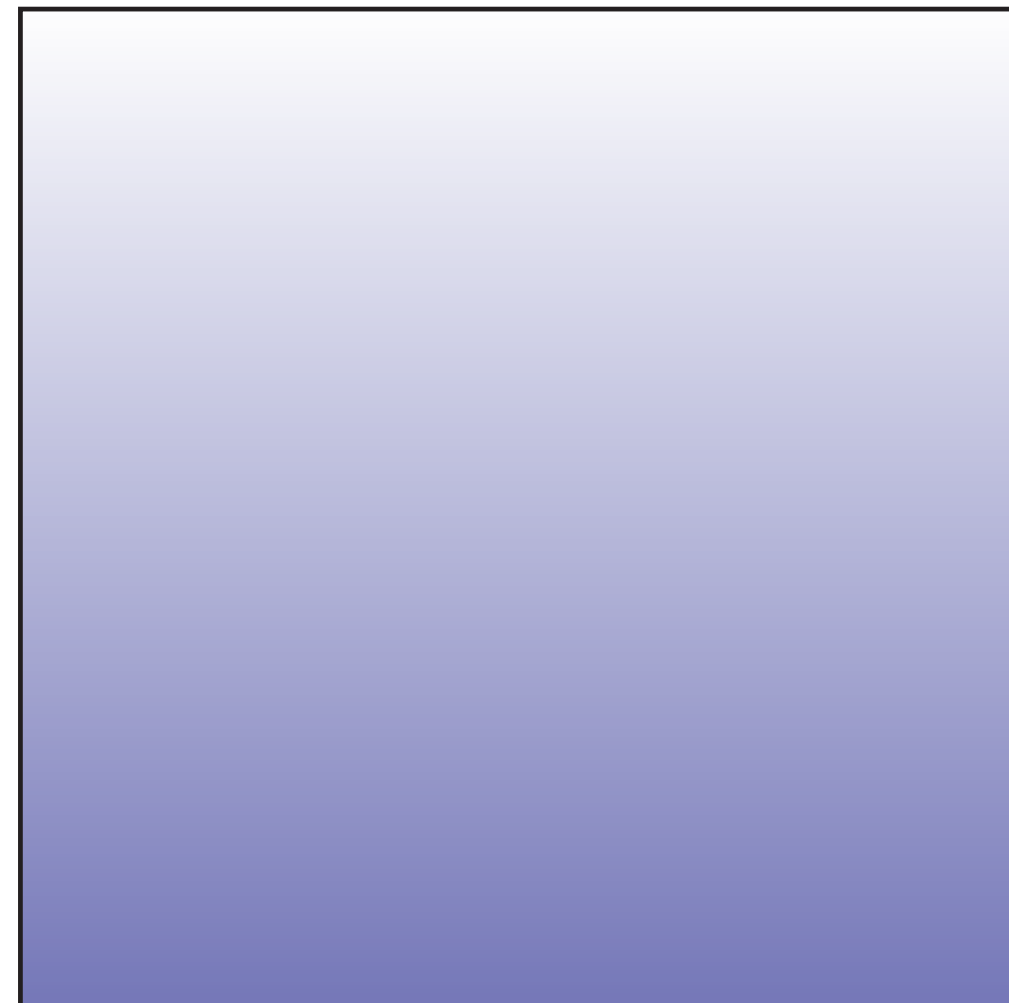
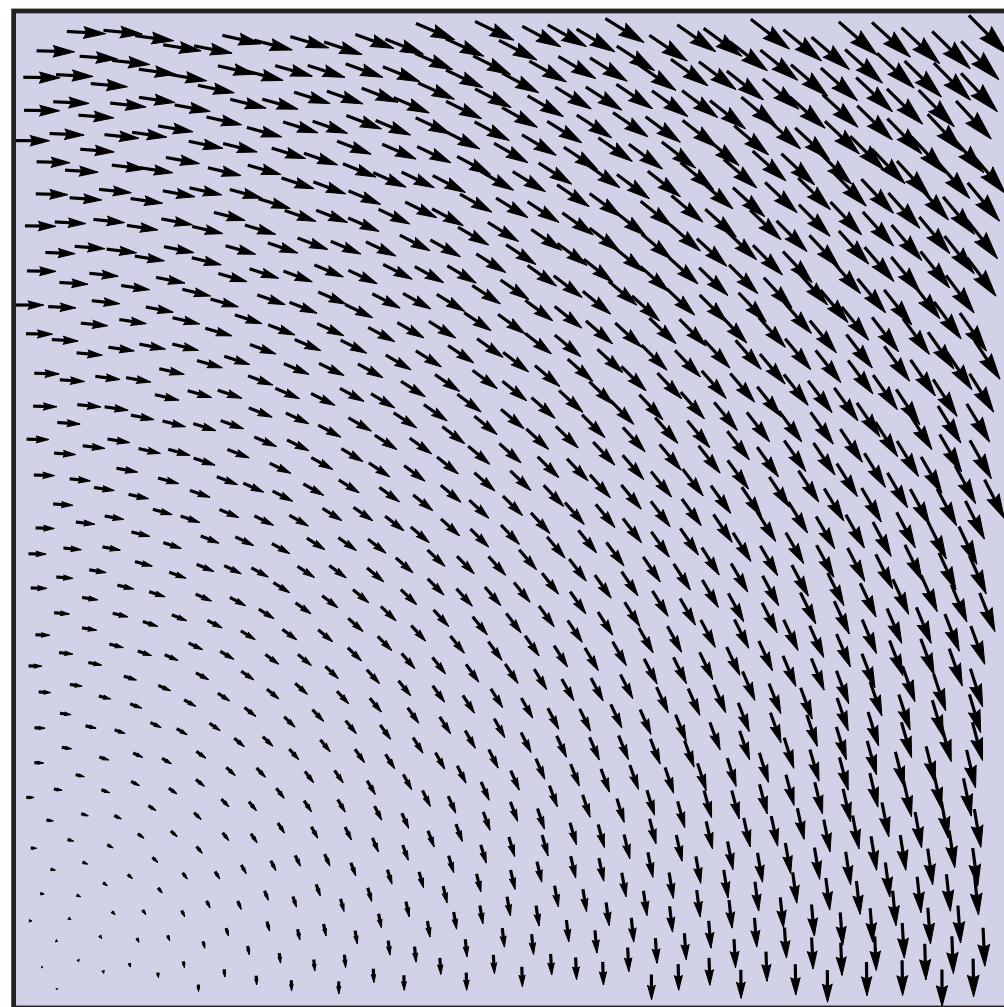

$\star\alpha \wedge \beta$

Example. Consider two 1-forms on the unit square $[0, 1] \times [0, 1]$ given by

$$\begin{aligned}\alpha &:= du, \\ \beta &:= v du - u dv.\end{aligned}$$

Their inner product is

$$\begin{aligned}\langle\langle\alpha, \beta\rangle\rangle &= \int_0^1 \int_0^1 (\star\alpha) \wedge \beta = \\ &= \int_0^1 \int_0^1 dv \wedge (v du - u dv) = \\ &= - \int_0^1 \int_0^1 v du \wedge dv = -\frac{1}{2}.\end{aligned}$$



Summary

Exterior Calculus — Summary

- **What we've seen so far:**
- *Exterior algebra*: language of volumes (k -vectors)
- k -form: measures a k -dimensional volume
- *Differential forms*: k -form at each point of space
- *Exterior calculus*: differentiate / integrate forms
- *Simplicial complex*: mesh made of vertices, edges, triangles...
- **Next up:**
 - Put all this machinery together
 - *Integrate* to get discrete exterior calculus (DEC)

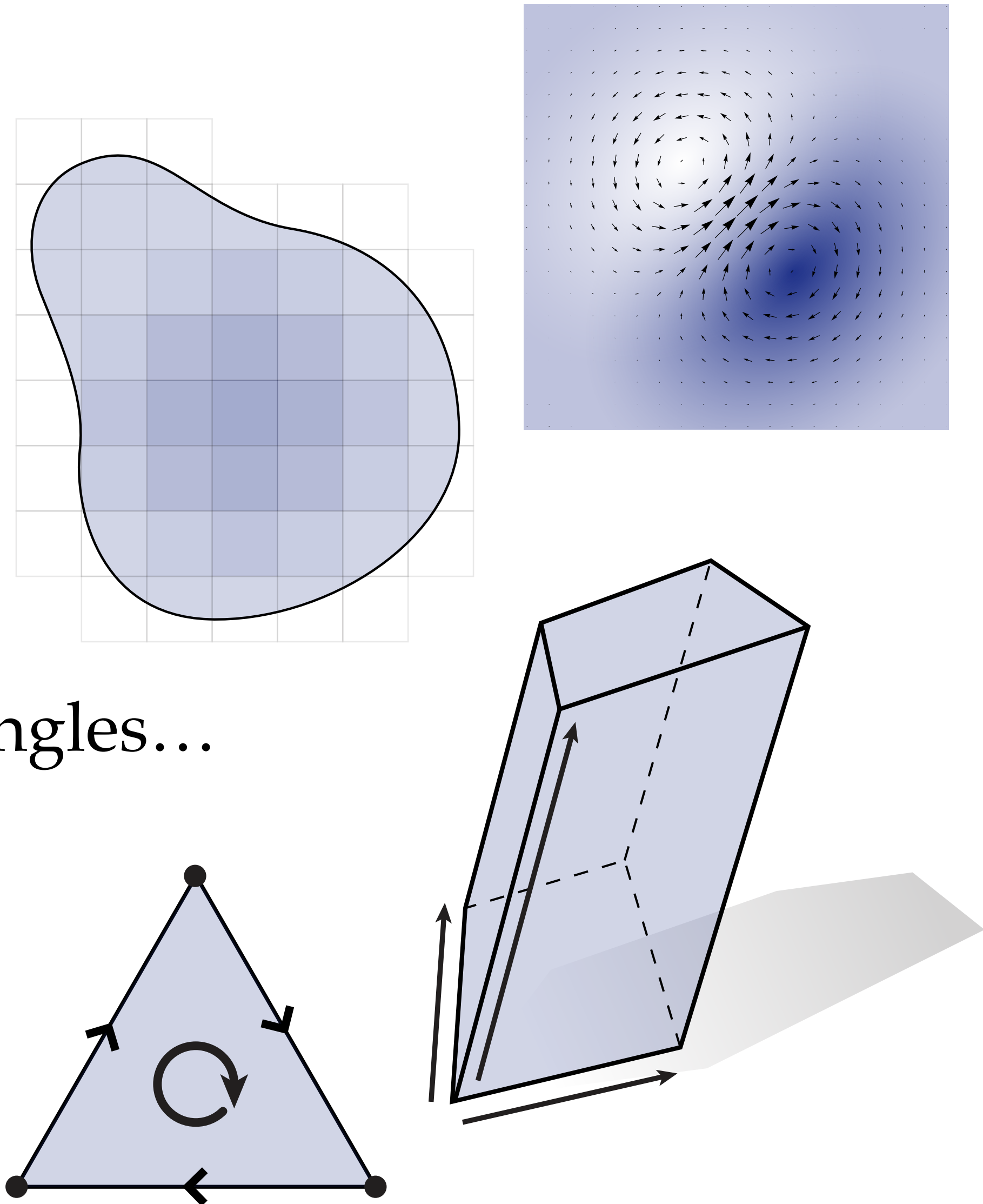

Thanks!

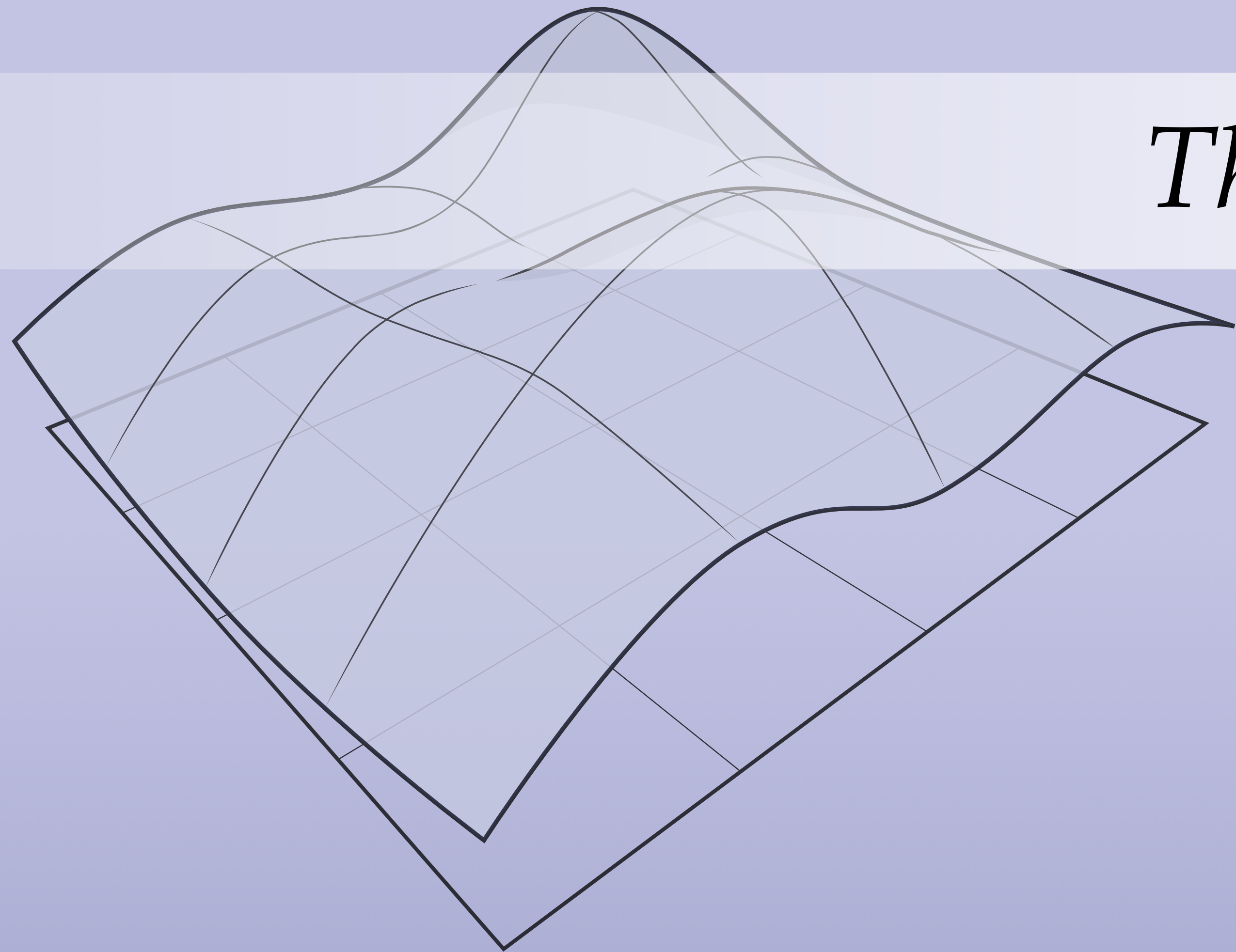

DISCRETE DIFFERENTIAL GEOMETRY
AN APPLIED INTRODUCTION